



Huntleigh
HEALTHCARE

Mini Pump Service Manual

AMENDMENT RECORD

Amendment	Incorporated by	Date
1		
2		
3		
4		
5		
6		
7		
8		
9		
10		
11		
12		
13		
14		
15		
16		
17		
18		
19		
20		
21		
22		
23		
24		
25		
26		
27		
28		
29		
30		

Contents

CHAPTER 1

Introduction	1
About This Manual	1
Warnings, Cautions and Notes	2
Technical Description	3
Operating Principle	3
System Start Up Sequence	5
Low Pressure Alarm (Electronic Units Only)	6
Low Pressure Alarm (All Units)	6
Low Pressure Alarm Protocol (Electronic Units Only)	6
Power Failure Alarm (Electronic Units Only)	6
Battery Management (Electronic Units Only)	7

CHAPTER 2

Maintenance	1
Pump Maintenance Checks	1
Pump Soak/Break-in Times	2
Pump Service	2

CHAPTER 3

Pump Repair	1
General	1
Removing the Pressure Control Knob	3
Installing the Pressure Control Knob	3
Disassembling the Pump Filter	5
Assembling the Pump Filter	5
Disassembling the Rear Case	5
Assembling the Rear Case	5
Disassembling the New Style Bed Hook	7
Installing the New Style Bed Hook	7
Removing the Old Style Bed Hook	9
Installing the Old Style Bed Hook	9
Removing the Compressor Inlet Filter	11
Installing the Compressor Inlet Filter	11
Removing the New Style AV Mounts	13
Replacing the New Style AV Mounts	13
Removing the Old Style AV Mounts	15

Installing the Old Style AV Mounts 15

Removing the Compressor Mounting Bracket. 17

Installing the Compressor Mounting Bracket 17

Removing the Compressor Bump Stops 17

Installing the Compressor Bump Stops 18

Replacing the Compressor Silencer Bag 19

Replacing the Bellows Armature Assemblies and Pivots 21

Replacing the Compressor Armature Pivots 21

Replacing the Compressor Valve Bodies 23

Replacing the 'E' Stack Assembly. 25

Replacing the Coil Assembly 25

Replacing the Compressor Assembly 25

Replacing the Pressure Control Module. 27

Replacing the Alarm Monitoring PCB 29

Changing the Battery 31

Replacing the Neon Indicator Light 33

Replacing the Microswitch. 35

Replacing the Terminal Block 35

Replacing the Pressure Control Flaps and Air Bag 37

Replacing the Pressure Control Assembly 39

Replacing the Synchronous Motor (Gearbox), Rotor Stator Assembly 41

Replacing the Side Panel Mains/Power On/Off Switch 43

Replacing the Side Panel Mains/Power Lead 43

Replacing the Fuses. 43

Replacing the Snap-lock Connectors 45

Removing the Front Case 46

Installing the Front Case 46

Pump Label Sets 47

CHAPTER 4

Troubleshooting 1

 General 1

 Low Pressure fault indicated (checks without dismantling the pump) 2

 Loss of Output Pressure (checks by dismantling the pump) 3

 Low Pressure Alarm Fault 4

 Air Not Alternating (continuous pressure fault) 4

 Loss of Electrical Power 4

Circuit Diagrams	5
CHAPTER 5	
Testing	1
Pump Flow, Pressure and Function Test.	1
Electrical Testing	5
PCB Functional Tests (Electrical Units Only).	6
Functional Tests (Mechanical Units Only)	7
CHAPTER 6	
Technical specification.	1
CHAPTER 7	
Parts list.	1
CHAPTER 8	
Service Contact Details	1

CHAPTER 1

INTRODUCTION

1 About This Manual

Huntleigh Healthcare strongly recommend that their equipment is only serviced by trained personnel and provide courses for customers who wish to become licensed to service their own equipment. In no event will Huntleigh Healthcare be responsible for any service performed by customers or third parties.

This manual contains information on maintenance, servicing, repair, troubleshooting and testing for the range of pressure regulated pump units; pump models within the range are as follows:

- AlphaXcell (Electronic)AlphaXcell (Mechanical)
- AlphaRelief (Electronic)
- Aura (Electronic)
- AlphaTrancell (Mechanical)
- AlphaBed (Mechanical)
- AlphaCare (Mechanical)

Pump models are available for use world wide – model codes are shown in Table 1, while for country codes and power supply details refer to Table 2.

Table 1 - Product Range Distribution

Model	Code	Country Code
AlphaXcell (Electronic)	ALX	01 to 10
AlphaXcell (Mechanical)	ALX	11
AlphaRelief	ALR	01 - 10
Aura	ALS	01 - 10
AlphaTrancell	ALT	01 - 10
AlphaBed	ALB	01 - 10
AlphaCare	ALC	01 - 10

Table 2- Country Codes/Power Supplies

Country Code	Country	Mains Power	
		Voltage (Volts AC)	Frequency (Hz)
01	UK	220 - 240	50
02	Germany	220 - 240	50
03	USA	110 - 120	60
04	Euro	220 - 240	50
05	France	220 - 240	50
06	Japan	100	50/60
07	Italy	220 - 240	50
08	Australia	220 - 240	50
09	Rest of World	220 - 240	50
10	Holland	220 - 240	50
11	Rest of World	110 - 120	60

Warnings, Cautions and Notes

WARNINGS given in this manual identify possible hazards in procedures or conditions which, if not correctly followed, could result in death, injury or other serious adverse reactions.

Cautions given in this manual identify possible hazards in procedures or conditions which, if not correctly followed, could result in equipment failure or damage.

Notes given in this manual are used to explain or amplify a procedure or condition.

WARNINGS:

BEFORE PERFORMING ANY SERVICE OR MAINTENANCE PROCEDURES, ENSURE THAT THE EQUIPMENT HAS BEEN ADEQUATELY DECONTAMINATED.

VOLTAGES IN EXCESS OF 30 VOLTS RMS OR 50 VOLTS DC CAN, IN CERTAIN CIRCUMSTANCES, BE LETHAL. WHEN WORKING ON EQUIPMENT REQUIRING EXPOSURE TO LIVE, UNPROTECTED CONDUCTORS WHERE SUCH VOLTAGES ARE PRESENT, EXTREME CARE MUST BE EXERCISED.

WHEN AN UNSERVICEABLE MAINS LEAD/POWER CORD FITTED WITH A NON-REWIREABLE PLUG IS REMOVED FROM THIS EQUIPMENT, THE LEAD/CORD AND THE PLUG MUST BE DESTROYED AND DISPOSED OF SAFELY. TO AVOID THE DANGER OF ELECTRIC SHOCK THE PLUG MUST NEVER BE INSERTED IN ANY POWER OUTLET.

2 Technical Description

The pressure regulated pump units listed in section 1 provide pressurised air for alternating pressure mattress systems which are used in aiding the prevention, treatment and management of pressure ulcers.

Pressurised air is fed to a range of support systems, mattresses, seat cushions etc., which support patients at risk of developing pressure ulcers.

All pumps are self-contained units powered by the single phase mains/power supply. Low air pressure and power failure alarm functions are included in some models, and pump output pressure is adjustable by means of a rotary control mounted on the unit front panel.

Operating Principle

Refer to Figure 1 for details of the pneumatic circuit. All pumps have two pressurised air outlets, air from the outlets is fed to separate cells or groups of cells in the mattress or cushion via a rotary valve. The support cells are continuously inflated and deflated utilising a ten minute cycle. During the cycle, air is pumped from one outlet for 4 minutes 10 seconds, there is then a period of 50 seconds where air is pumped from both outlets. Air is then pumped from the other outlet for 4 minutes 10 seconds, followed by a 50 second period where air is supplied from both outlets. During the period when air is supplied from a single outlet to one group of cells, the opposing outlet is vented to atmosphere, deflating the corresponding cells.

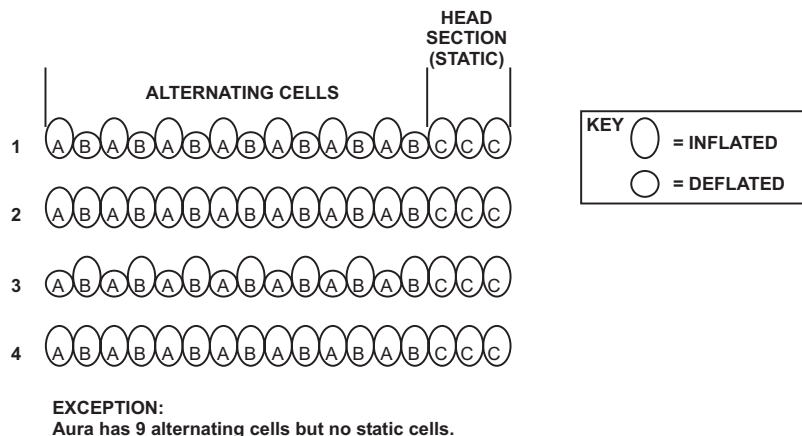
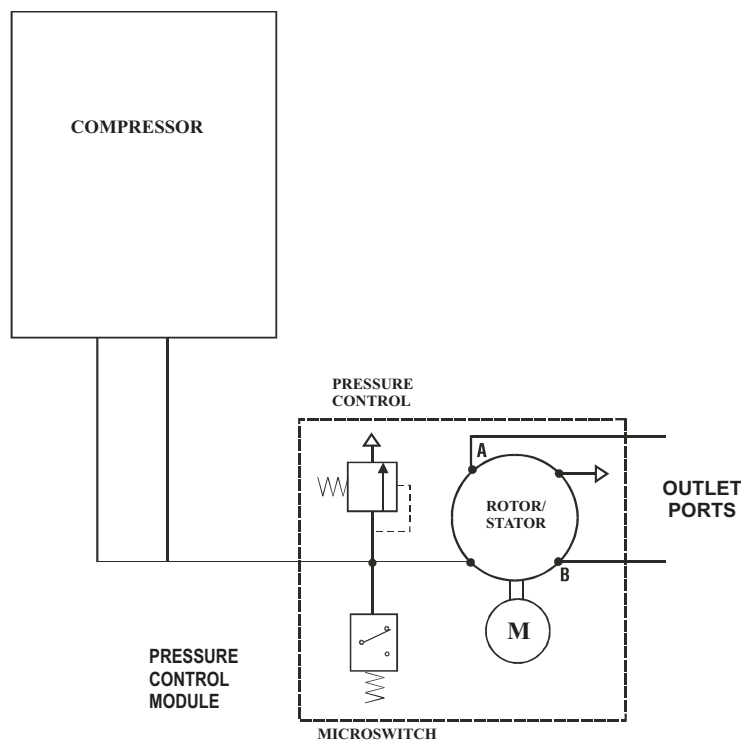

Figure 1 - Pneumatic Diagram and Pressure Variations

For the Aura mini pump small adjustments can be made to cell pressure using the comfort control knob on the pump unit. This is a patient comfort feature to make small adjustments to the softness or firmness of the support cells. All other mini pumps have a pressure adjustment control that must be set to the patient weight in accordance with the instructions given in the relevant user manual and/or the pump labels.

The range of air pressure delivered by the series of pumps varies, as does the achievable flow rate. One extreme of pressure range can be adjusted by obtaining access to a screw under the pressure control knob; see Table 3 for details of pressure variations. The range achievable is fixed by the pressure control spring, only the set pressure can be reset.

Table 3 - Air Pressure/Flow Rates

Pump Model	Minimum Pressure (mmHg)	Maximum Pressure (mmHg)	Adjustable Pressure Range	Minimum Flow Rate at 20 mmHg back pressure (litres/minute)	Minimum Flow Rate at 50 mmHg (litres/minute)
ALX	20-24	57-73	Yes	6	3
ALR	20-24	72-92	Yes	6	3
ALS	83-87	Less than 110	Comfort control only	3.25	2.25
ALT	25-35	65-81*	Yes	6	3
ALB	25-35	80-100	Yes	6	3
ALC	25-35	80-100	Yes	6	3

* Holland pumps (ALT10) only - max pressure is 80-100 mmHg

Pump units may be divided, into two types, Mechanical and Electronic. Major differences between the two types of pump unit are as follows:

- Alarm indicators - mechanical type has a neon indicating low air pressure, also an illuminated mains/power on/off switch. The electronic type incorporates an alarm monitoring PCB driving a number of LED indicators and audible warning sounder. See Table 4 for visual indicator details.
- Air outlets - mechanical type has simple push-on connectors (except ALX11 which has snap-lock type connectors). The electronic type utilises snap-lock type connectors.

Table 4 - Product Visual Indicators

Model Code	ALB	ALC	ALT	ALR	ALX	ALX	ALS
Mechanical (M) or Electrical (E)	M	M	M	E	E	M	E
Indicator							
Illuminated Mains/Power Switch	X	X	X			X	
On				X	X		X
Wait				X	X		
Low Pressure	X	X	X	X	X	X	X
Power Fail				X	X		X

System Start Up Sequence

All pump types must be connected to the appropriate mains/power supply via a suitable plug.

After a mechanical pump is switched on the start up sequence is as follows:

- The ON/OFF switch lever will be illuminated green.

- The red 'low pressure' indicator will be illuminated. When operating pressure is achieved, the low pressure indicator will be extinguished automatically.

After an electronic pump is switched to 'Run' the start up sequence is as follows:

- The unit performs a diagnostic self test, illuminating all LED indicators and sounding the audible alarm. If an internal fault is sensed or a problem with the wiring of the mains/power sense switch, the pump will remain in this state. If the self test is successful then the start up sequence will proceed.
- On start up, the low pressure alarm will be inhibited until one minute after the low pressure signal is deactivated. The amber **WAIT** indicator will be illuminated while the low pressure alarm is inhibited. (See *Low pressure Protocol*) Other functions will work as normal.

*Note: Aura (ALS) model has no **WAIT** indicator; apart from this one difference, however, the Aura pump performs the same as the other electronic pump units.*

Low Pressure Alarm (Electronic Units Only)

When the alarm is activated, the red **LOW PRESSURE** indicator will flash, in combination with an audible warning which increases in pitch with time. The alarm can be reset by momentarily switching the pump to 'Stand by' and then back to 'Run'. Alternatively, the alarm will automatically reset after 15 minutes provided that the low pressure switch is not activated during this time. If however the low pressure switch is activated (for more than 15 seconds) during this time, the timer will reset to zero and the alarm will continue for a further 15 minutes.

Low Pressure Alarm (All Units)

On all pump units except the ALS model the low air pressure alarm will be activated on or before 5 mmHg and deactivated before the pressure reaches 17 mmHg.

For the ALS model only, the low air pressure alarm will be activated on or before 50 mmHg and deactivated at or before 82 mmHg.

Low Pressure Alarm Protocol (Electronic Units Only)

The low pressure alarm will be activated only when the requirements of the low pressure alarm protocol have been met by a sequence of low pressure signals. The system is designed to detect low pressure fault conditions without responding to spurious signals due to patient movement, mattress cell crossover, short term tube disconnection etc.

In order to generate a low pressure alarm the system must detect three low pressure switch closure, of 15 seconds duration each, within a 25 minute period. There will be a 2 minute lockout between the first and second switch closures as well as between second and third switch closures. The lockout period is to allow temporary disconnection of tubing.

In addition to the above, a wait period of 25 minutes is allowed on start up. During this time the low pressure alarm is inhibited to allow inflation of the mattress to operating pressure. If, during this wait period, the low pressure switch is activated (i.e., the system is up to pressure), the wait period will be terminated 1 minute later, and normal protocol is obeyed thereafter.

Power Failure Alarm (Electronic Units Only)

In the event of a power failure, the red **POWER FAIL** indicator will flash in combination with an audible warning which increases with time.

If the power supply is restored, the audible alarm will stop, but the indicator will remain illuminated (continuously) until the system is reset. Resetting, by switching the pump to 'Stand by' and then back to 'Run', will clear all alarm indications.

The power failure alarm is initiated by the removal of the mains/power supply from the unit for a period of more than 5 seconds, by a means other than operation of the 'Run/Standby' switch. A drop in the supply voltage below the minimum supply specification will be interpreted as a supply failure. If power is restored within 5 seconds, no alarm is given and normal operation is resumed.

A battery backup supply provides power to operate the visual and audible alarm.

Battery Management (Electronic Units Only)

On switching the pump to 'Run', the processor automatically initiates a standard charge sequence (3 mA) for a predetermined period. On completion of the standard charge period, a trickle charge (0.9 mA) will be applied to the battery for the remainder of the operating period.

When discharging during a power failure alarm, the battery supply will be shut down in a controlled manner if the terminal voltage falls below 4.6 V before the alarm duration has expired.

CHAPTER 2

MAINTENANCE

1 Pump Maintenance Checks

If any parts are found to be damaged they must be replaced in accordance with Chapter 3, Pump Repair.

1.1 Visually inspect the following for damage, wear and potential faults:

Note : If any parts require repairing or replacing then refer to the Huntleigh Healthcare service manual.

- 1.1.1 Check outer casings for damage.
- 1.1.2 Functionally check switches and control knobs.
- 1.1.3 Ensure hanging brackets are secure and located.
- 1.1.4 Check outlet ports and connecting points for damage.
- 1.1.5 Ensure feet are secure and present.
- 1.1.6 Check fuses are satisfactory.
- 1.1.7 If a gauge is fitted ensure the glass is not cracked or damaged.
- 1.1.8 Check that there is no damage to the mains/power connector if fitted.
- 1.1.9 Check labels are present, located correctly and legible.
- 1.1.10 Ensure LED's are not cracked.

1.2 Remove the compressor lid (Refer to Chap. 3, Section 22) and visually inspect the following for damage, wear, and potential faults:

Note : If any parts require repairing or replacing then refer to Chap 3, Pump Repair.

- 1.2.1 Coil/'E' stack assembly.
- 1.2.2 Elbows and connectors.
- 1.2.3 Bellows.
- 1.2.4 Security of compressor.
- 1.2.5 Integrity of filters and gaskets.
- 1.2.6 Valve body assembly.
- 1.2.7 Armature blades.
- 1.2.8 Pivot points.
- 1.2.9 Silencer bags.
- 1.2.10 Valve shuttle assembly.

Once the compressor has been visually inspected connect to a power supply and run, this is to ensure the compressor is working and that there is flow/pressure at the outlet port of the pump.

Check for any excessive noise and vibration.

2 Pump Soak/Break-in Times

2.1 A pump must be soaked/broken-in for the following reasons:

Note : Soaking/breaking-in consists of running the pump with the outlet ports blocked.

- To ensure that the pump is at normal running temperature prior to pneumatic performance tests being carried out.
- To stress test major/critical parts which have been replaced or repaired.

2.2 All pumps should be soaked/broken-in for a period of 30 to 60 minutes prior to any pneumatic performance test being carried out. This is because the compressor bellows need to warm up to reach normal output.

2.3 If any of the following major/critical components have been replaced or repaired, then it is recommended that the pump be soaked/broken-in for 12 hours prior to being tested:

- Valve body.
- Silencer Bag.
- Printed Circuit Boards (PCB) if applicable.
- Compressor.
- Rotary Valve Assembly.

3 Pump Service

A pump should be serviced every 12 months. To carry out a service on the pump, do the following:

3.1 Carry out the Pump Maintenance Checks (Section 1).

3.2 Replace the following components:

3.2.1 Silencer bag (Refer to Chapter 3, Section 22).

3.2.2 Pivot points (Refer to Chapter 3, Section 24).

3.2.3 Bellow assemblies (Refer to Chapter 3, Section 23).

3.2.4 Valve bodies (Refer to Chapter 3, Section 25).

3.2.5 Compressor filter (Refer to Chapter 3, Section 12).

3.2.6 Compressor gasket (Refer to Chapter 3, Section 22).

3.2.7 Pump case filter (Refer to Chapter 3, Section 4).

3.2.8 AV mounts (Refer to Chapter 3, Section 14 - new style, Section 16 - old style).

3.2.9 Internal rechargeable battery (Refer to Chapter 3, Section 31).

- 3.3 Reassemble the pump and soak/break-in for the recommended time (Refer to Section 2).
- 3.4 Carry out a flow, pressure and function test on the pump in accordance with Chapter 5.
- 3.5 Carry out electrical tests on the pump in accordance with Chapter 5.

CHAPTER 3

PUMP REPAIR

1 General

This chapter details repair procedures for the range of pump units listed in Chapter 1, Page 1, Table 1. All repairs should be carried out by Huntleigh approved service personnel.

After carrying out a service or any repairs, the pump must be soak tested/broken-in for the recommended time (Refer to Chapter 2) and tested for serviceability. The table below defines the test requirements which must be carried out following certain repairs:

To carry out a flow, pressure and function test on the pump refer to Chapter 5.

To carry out the electrical tests on the pump refer to Chapter 5.

Table 5- Repair to Testing Requirements

Components / Assemblies	Flow/Pressure & Function Test	Electrical Safety
Compressor	Yes	Yes
Pressure Control	Yes	Yes
Rotors & Stators	Yes	Yes
Silencer Bag	Yes	No
Coils	Yes	Yes
Elbows & Connectors	Yes	No
AV Mounts	Yes	Yes
PCB	Yes	Yes
Front Casing	Yes	No
Rear Casing	No	No
Battery	No	Yes
Switches	No	Yes
Fuse	No	Yes
Electrical Connectors	No	Yes
Mains/Power Lead	No	Yes

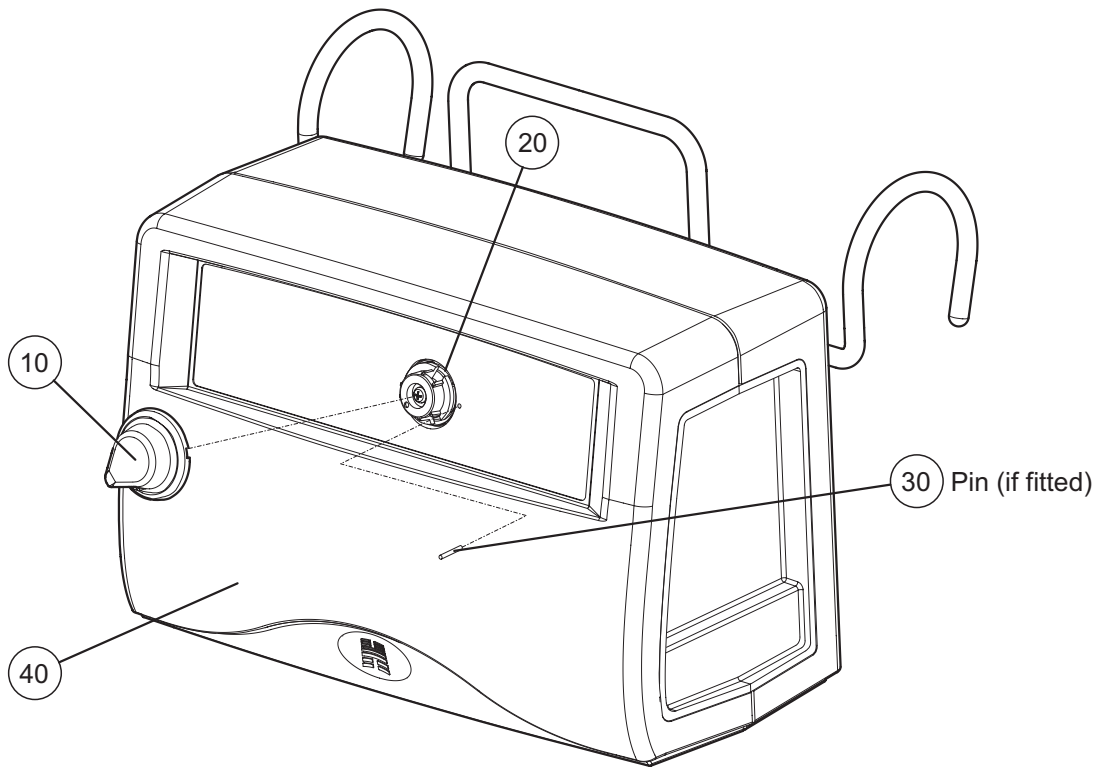

Figure 2 - Removing the Control Knob

Table 6 - Control Knob Part List

Item	Part Number	Description	Qty
10	500484	Control Knob (MK2)	1
20	500304	Knob Arbour	1
30	500318	Pin (if fitted)	1
40	500316	Front Case	1

Note : The obsolete MK1 control knobs are fully interchangeable with the MK2 control knobs. If the MK1 control knob needs replacing, replace it with the MK2 version.

2 Removing the Pressure Control Knob

Note : Removing the control knob avoids possible damage and allows the pump to sit on a flat surface without rocking.

- 2.1 Locate the slot at the rear of knob (Fig 2, Item 10) and insert a 3 mm flatpoint screwdriver.
- 2.2 Lever the screwdriver upward to lift the knob off the three retaining prongs.

3 Installing the Pressure Control Knob

Note : When installing the pressure control knob, ensure that the small prong sits in its own housing. Then, the two larger prongs will line up correctly.

Aura (Pin fitted)

Turn knob arbour clockwise to it's full extent. Fit control knob in the position shown below.

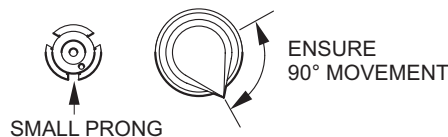

AlphaRelief / AlphaBed / AlphaCare / AlphaTrancell ALT10 (No pin fitted)

Turn knob arbour counter-clockwise to it's full extent. Fit control knob in the position shown below.

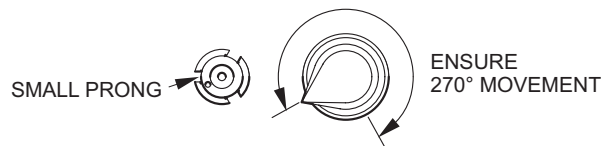

AlphaXcell / AlphaTrancell ALT01-09 (Pin fitted)

Turn knob arbour counter-clockwise to it's full extent. Fit control knob in the position shown below.

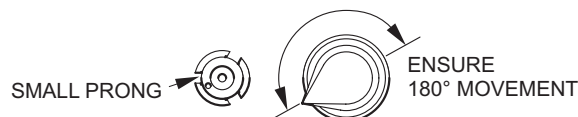

- 3.1 Carefully position the knob (Fig 2, Item 10) so that the prongs are correctly aligned with the recesses in the knob arbour (Fig 2, Item 20)
- 3.2 Press the knob into place on the arbour and ensure that it is correctly seated.

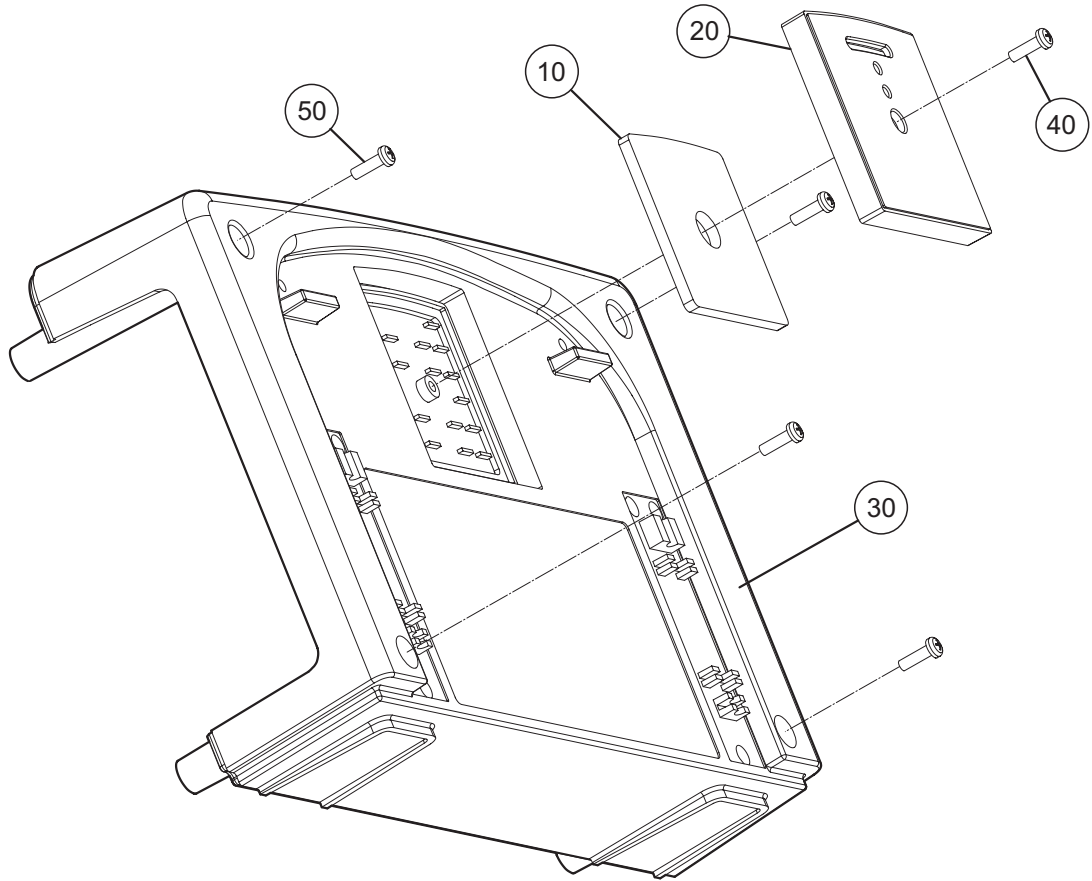

Figure 3 - Removing and Replacing the Pump Filter

Table 7 - Pump Filter Part List

Item	Part Number	Description	Qty
10	500340	Felt Filter	1
20	500327	Filter Plate	1
30	500317	Rear Case	1
40	FAS223	Pan Head Screw PT 3 Dia x 10 Pozi	1
50	FAS225	Pan Head Screw PT 3 Dia. x 16 Pozi	4

4 Disassembling the Pump Filter

- 4.1 Remove the centre screw (Fig 3, Item 40) retaining the filter plate (Fig 3, Item 20) in the rear case (Fig 3, Item 30).
- 4.2 Carefully remove the filter plate and felt filter (Fig 3, Item 10) from the rear case. Discard the old filter.

5 Assembling the Pump Filter

- 5.1 Install a new filter (Fig 3, Item 10) in the filter plate (Fig 3, Item 20) ensuring that the curved edge is at the top.
- 5.2 Ensure that the filter is correctly positioned over the boss in the filter plate then fit the filter plate to the rear case (Fig 3, Item 30) and secure with the screw (Fig 3, Item 40).

6 Disassembling the Rear Case

Note : It is necessary to remove the rear case from the front case to allow access to all internal pump connections.

- 6.1 Remove the front panel control knob (Refer to Page 3, Section 2).
- 6.2 Place the pump on a flat, clean surface with the case front face down.
- 6.3 Unscrew and remove the four corner screws (Fig 3, Item 50).
- 6.4 Carefully remove the rear case assembly (Fig 3, Item 30) from the case front.

7 Assembling the Rear Case

- 7.1 Assembly of the rear case is in the reverse order of disassembly.

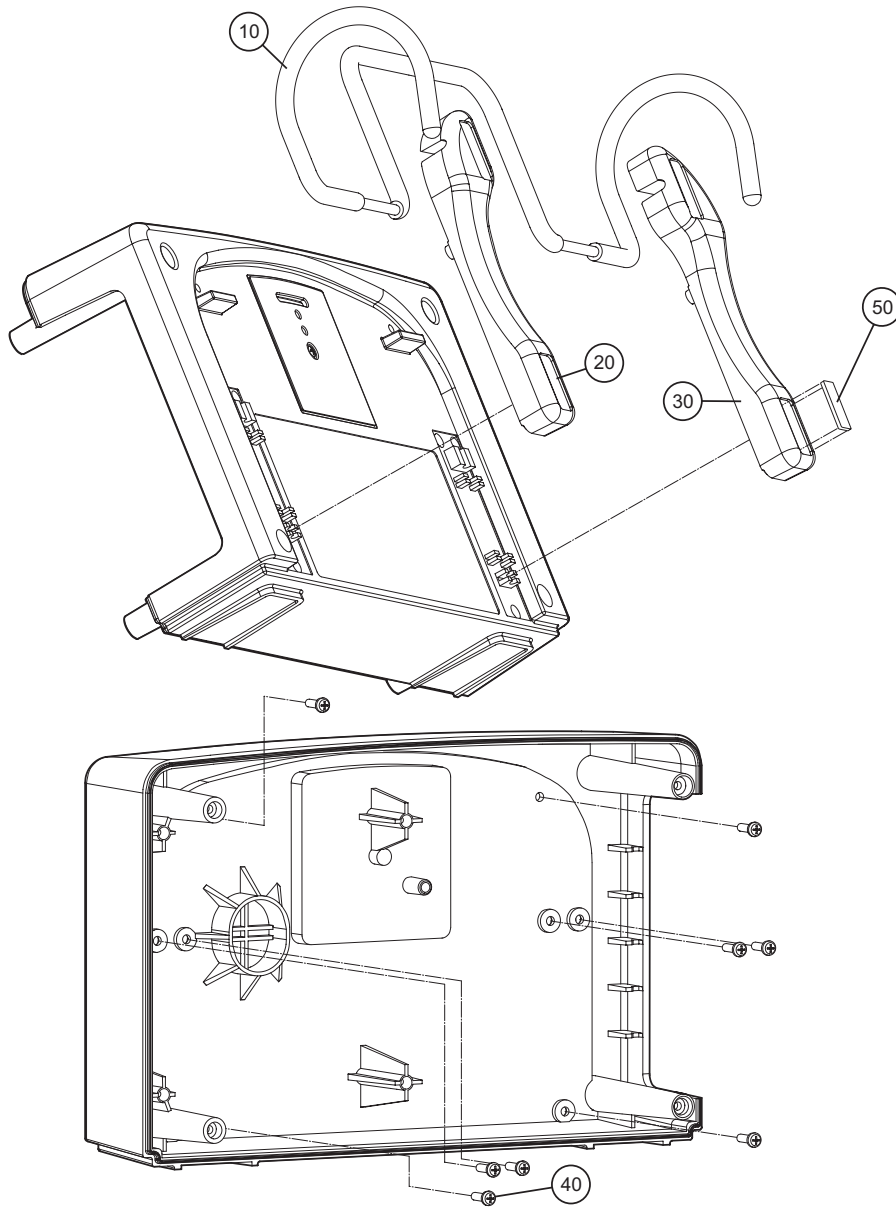

Figure 4 - Replacing the New Style Bed Hook

Table 8 - New Style Bed Hook Part List

Item	Part Number	Description	Qty
10	500495	Bed Hook (New Style)	1
20	500496	Hook Plate (Left Hand)	1
30	500497	Hook Plate (Right Hand)	1
40	FAS223	Pan Head screw PT 3 Dia. x 10	8
50	500381	Rubber foot	8

8 Disassembling the New Style Bed Hook

- 8.1 Remove the pressure control knob from the pump (Refer to Page 3, Section 2).
- 8.2 Remove the pump rear case (Refer to Page 5, Section 6).

Note : The bed hook brackets are right and left handed.

- 8.3 Hold a hook plate (Fig 4, Item 20 or 30) in position and remove the four securing screws (Fig 4, Item 40) from the inside of the pump rear case. Release the hook plate from the rear case and lift clear.
- 8.4 If necessary repeat Section 8.3 to remove the other hook plate and bed hook (Fig 4, Item 10).

9 Installing the New Style Bed Hook

Note : Replacement Old Style Bed Hooks are no longer available. The Old Style Rear Case assembly will not accommodate the New Style Bed Hook so where Old Style Bed Hooks must be replaced it will be necessary to obtain all the parts listed in Table 8, plus the rear case (Item 30 in Table 6).

Note : For step 9.2, remember to place the left-hand bracket on the right and the right-hand bracket on the left, since their relative positions will be reversed when they are presented to the rear case assembly.

- 9.1 Assembly of the new Pump Filter is in the reverse order of disassembly. Make sure the slots in the Filter Housing Plates (Fig 4, Item 20) are uppermost in the positions shown in Fig 4.
- 9.2 Lay the left-hand (Fig 4, Item 20) and the right-hand (Fig 4, Item 30) brackets on a hard flat surface with their rubber pads face down and their shaped heads pointing inward.
- 9.3 Ensure the bed hook (Fig 4, Item 10) is correctly placed to the left-hand and right-hand slots where the coating has been removed. Firmly press home the bed hook until it clicks into place.
- 9.4 Lay the rear case assembly, on a hard flat surface, with its back uppermost. Turn over the bed hook subassembly and place into the rear case assembly.
- 9.5 Position one bracket and press it firmly until it clicks into place. Repeat this process for the other bracket.
- 9.6 Turn over the rear case assembly and fit four securing screws to each bracket.
- 9.7 Assemble the rear case to the pump (Refer to Page 5, Section 7).
- 9.8 Install the pressure control knob (Refer to Page 3, Section 3).

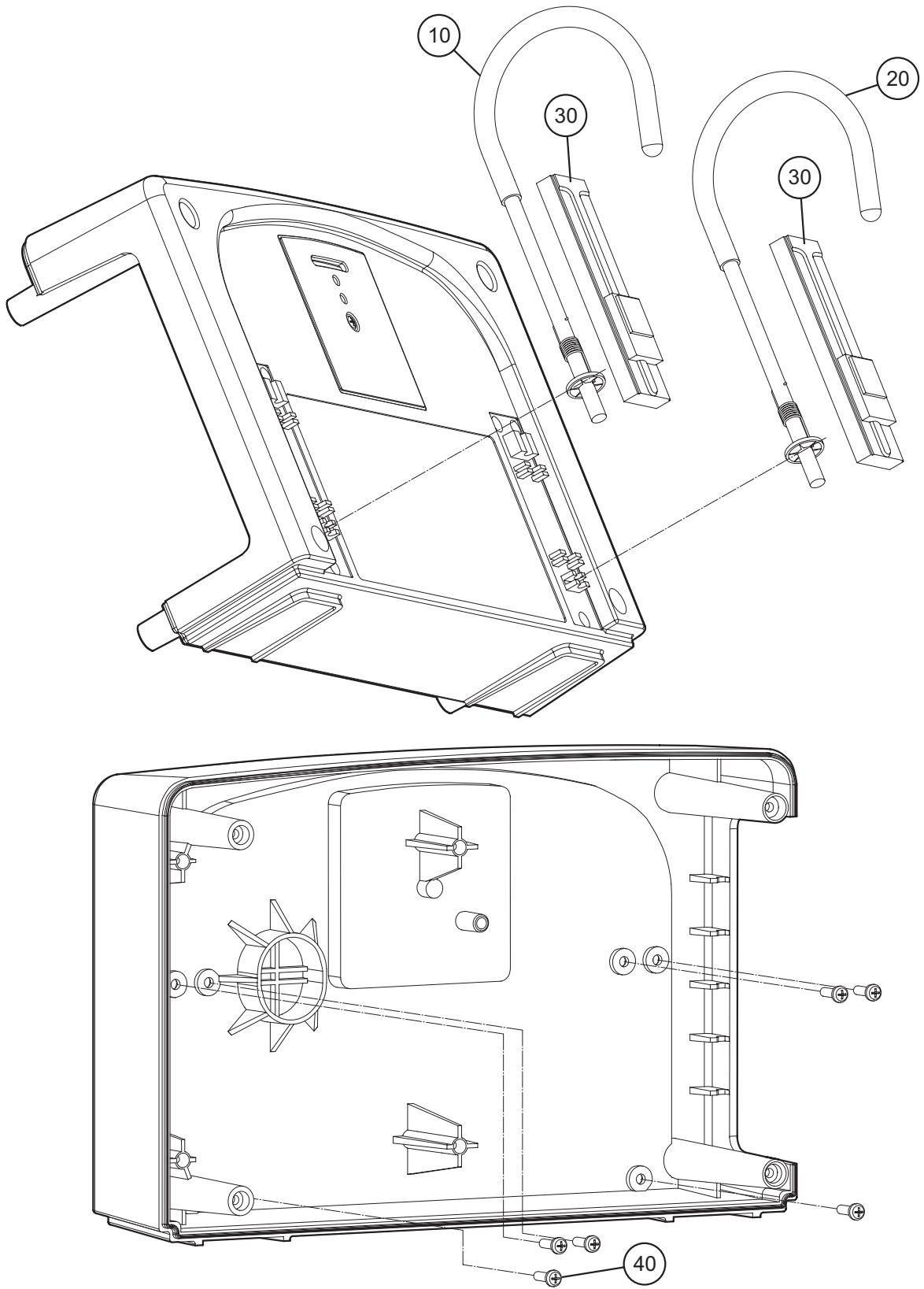

Figure 5 - Replacing the Old Style Bed Hooks

Table 9 - Old Style Bed Hook Part List

Item	Part Number	Description	Qty
10	N/A	Bed Hook - Left Hand	1
20	N/A	Bed Hook - Right Hand	1
30	N/A	Hook Plate	1
40	N/A	Pan Head screw PT 3 Dia. x 10 Pozi	6

Note :The old bed hook bracket assemblies are left and right handed. Replacements are no longer available.

10 Removing the Old Style Bed Hook

- 10.1 Remove the pressure control knob from the pump (Refer to Page 3, Section 2).
- 10.2 Remove the pump rear case (Refer to Page 5, Section 6).
- 10.3 Hold a hook plate (Fig 5, Item 30) in position and remove the three securing screws (Fig 5, Item 40) from the inside of the rear case.
- 10.4 Carefully remove the hook plate and its bed hook (Fig 5, Item 10 or 20).
- 10.5 Repeat Section 10.3 and 10.4 for the other hook plate and bed hook if required.

Note : The above procedure will not be necessary when changing the old bed hooks for the new bed hook which needs the new rear case assembly.

11 Installing the Old Style Bed Hook

- 11.1 When refitting the old bed hook brackets, replacement is the reversal of the above procedure.
- 11.2 Ensure correct orientation of the left and right-handed assemblies. (The spring on the right hand assembly is colour coded red).
- 11.3 Position the hook and spring assembly on the rear case, install the hook plate and hold it in place while inserting the three securing screws from the inside of the rear case.
- 11.4 Assemble the rear case to the pump (Refer to Page 5, Section 7).
- 11.5 Install the pressure control knob (Refer to Page 3, Section 3).

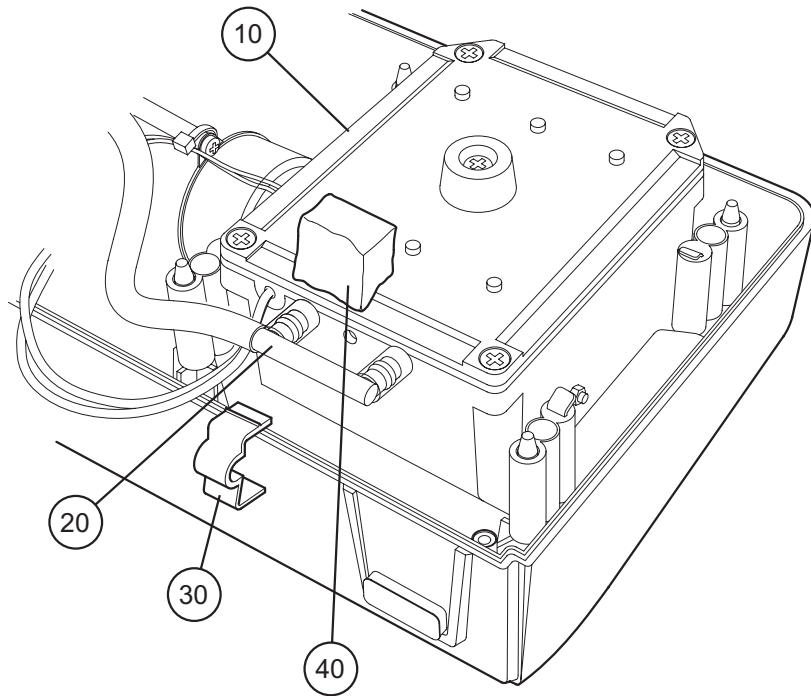

Figure 6 - Replacing the Compressor Filter Assembly

Table 10 - Compressor Filter Assembly Part List

Item	Part Number	Description	Qty
10	502003	Compressor Assy 230V 50Hz 11K/T	1
	502002	Compressor Assy 110V 60Hz 5K/T (USA)	1
	502007	Compressor Assy 100V 50/60Hz 4.5K/T (Japan)	1
20	500320	'F' Tube Connector	REF
30	500410	Filter Retaining Clip	1
40	500417	Inlet Filter	1

12 Removing the Compressor Inlet Filter

- 12.1 Remove the pressure control knob from the pump (Refer to Page 3, Section 2).
- 12.2 Remove the rear case assembly (Refer to Page 5, Section 6).
- 12.3 Carefully pull the filter retaining clip (Fig 6, Item 30) from the 'F' tube connector (Fig 6, Item 20).
- 12.4 Remove and discard the old inlet filter (Fig 6, Item 40).

13 Installing the Compressor Inlet Filter

- 13.1 Locate a new inlet filter (Fig 6, Item 40) over the air intake hole in the case of the compressor assembly (Fig 6, Item 10).
- 13.2 Carefully reposition the filter retaining Clip (Fig 6, Item 30) on the 'F' tube connector (Fig 6, Item 20) to retain the inlet filter (Fig 6, Item 40). Make sure the clip is fitted with the longer arm downward if appropriate.
- 13.3 Assemble the rear case to the pump (Refer to Page 5, Section 7).
- 13.4 Install the pressure control knob from the pump (Refer to Page 3, Section 3).

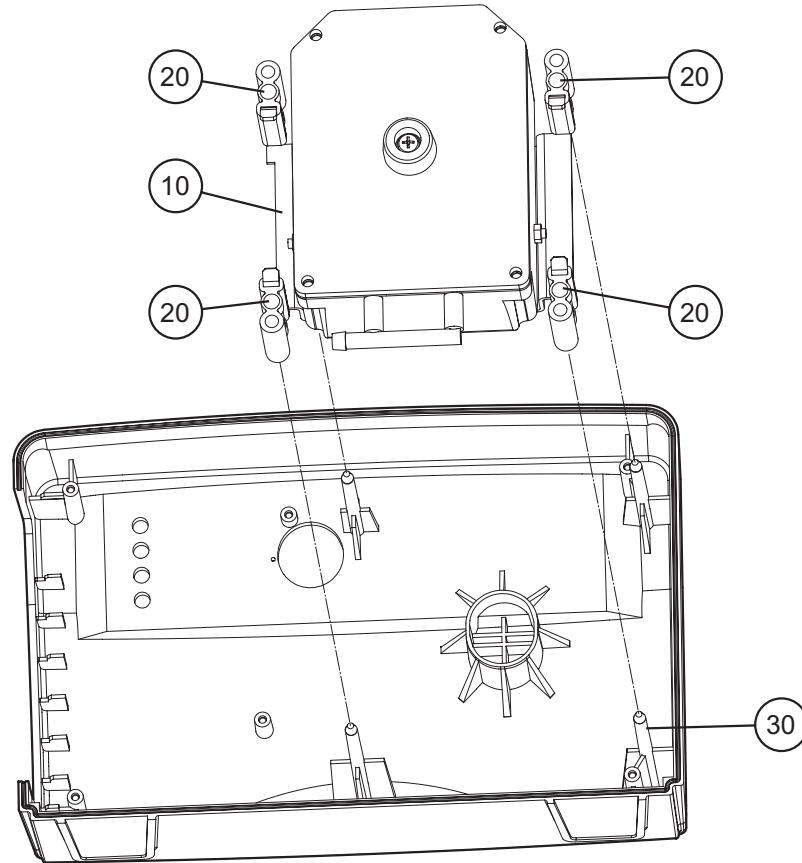

Figure 7 - Replacing the New Style AV Mounts

Table 11 - New Style AV Mounts Part List

Item	Part Number	Description	Qty
10	500124	Compressor Mounting Bracket	1
20	500416	AV Mount	4
30	N/A	Mounting Pins	4

14 Removing the New Style AV Mounts

- 14.1 Remove the pressure control knob from the pump (Refer to Page 3, Section 2).
- 14.2 Remove the rear case assembly (Refer to Page 5, Section 6).
- 14.3 Carefully lift the compressor, mounting bracket (Fig 7, Item 10) and AV mounts (Fig 7, Item 20) from the mounting pins (Fig 7, Item 30).
- 14.4 Remove the AV mounts from the mounting bracket and discard them.

15 Replacing the New Style AV Mounts

- 15.1 Fit new AV mounts (Fig 7, Item 20) of the same type to the mounting bracket (Fig 7, Item 10).
- 15.2 Carefully fit the compressor, mounting bracket and AV mounts to the mounting pins (Fig 7, Item 30) in the pump case. Ensure that all four AV mounts are correctly located on the mounting pins.
- 15.3 Assemble the rear case to the pump (Refer to Page 5, Section 7).
- 15.4 Assemble the pressure control knob to the pump (Refer to Page 3, Section 3).

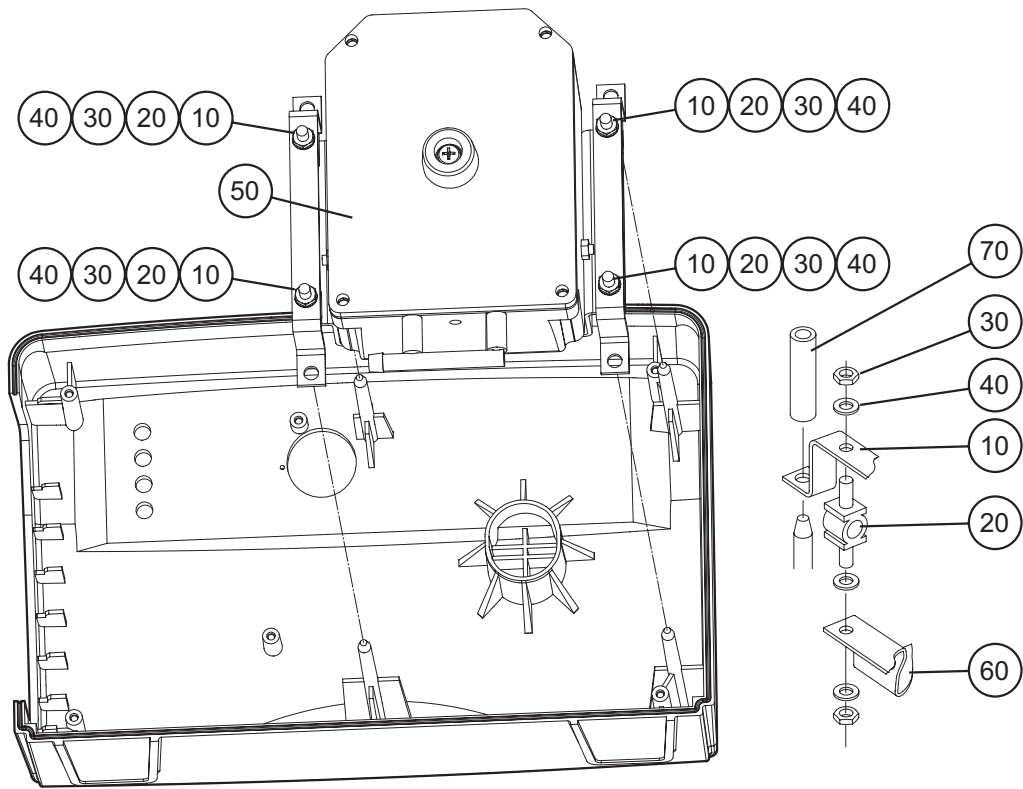

Figure 8 - Replacing the Old Style AV Mounts

Table 12 - Old Style AV Mounts Part List

Item	Part Number	Description	Qty
10	N/A	AV Mounting Bracket	2
20	198375	AV Mount	4
30	N/A	AV Mount Nut	8
40	N/A	Washer	12
50	Ref Table 14	Compressor	1
60	N/A	Compressor Mounting Bracket (Part)	1
70	N/A	Spacers	4

16 Removing the Old Style AV Mounts

Note : Replacements are not available for the old style AV mounts.

- 16.1 Remove the pressure control knob from the pump (Refer to Page 3, Section 2).
- 16.2 Remove the rear case assembly (Refer to Page 5, Section 6).
- 16.3 Remove the securing spacers (Fig 8 Item 70) and carefully lift the compressor (Fig 8, Item 50) and AV bracket assembly (Fig 8, Items 10, 20, 30, 40, 60) from the mountings.
- 16.4 Release the top AV mount nuts (Fig 8, Item 30) and washers (Fig 8, Item 40) and remove the two AV mounting brackets (Fig 8, Item 10) from the AV mounts (Fig 8, Item 20).
- 16.5 Release the bottom AV mount nuts and washers and remove the four AV mounts from the compressor mounting bracket (Fig 8, Item 60).

17 Installing the Old Style AV Mounts

- 17.1 Fit four replacement AV mounts (Fig 8, Item 20) to the compressor mounting bracket (Fig 8, Item 60) and secure with washers (Fig 8, Item 40) and nuts (Fig 8, Item 30).
- 17.2 Fit the two AV mounting brackets (Fig 8, Item 10) to the AV mounts and secure with washers and nuts.
- 17.3 Carefully fit the compressor (Fig 8, Item 50) and AV bracket assembly (Fig 8, Items 10, 20, 30, 40, 60) to the mountings in the pump case and fit securing spacers (Fig 8 Item 70).
- 17.4 Assemble the rear case to the pump (Refer to Page 5, Section 7).
- 17.5 Install the pressure control knob (Refer to Page 3, Section 3).

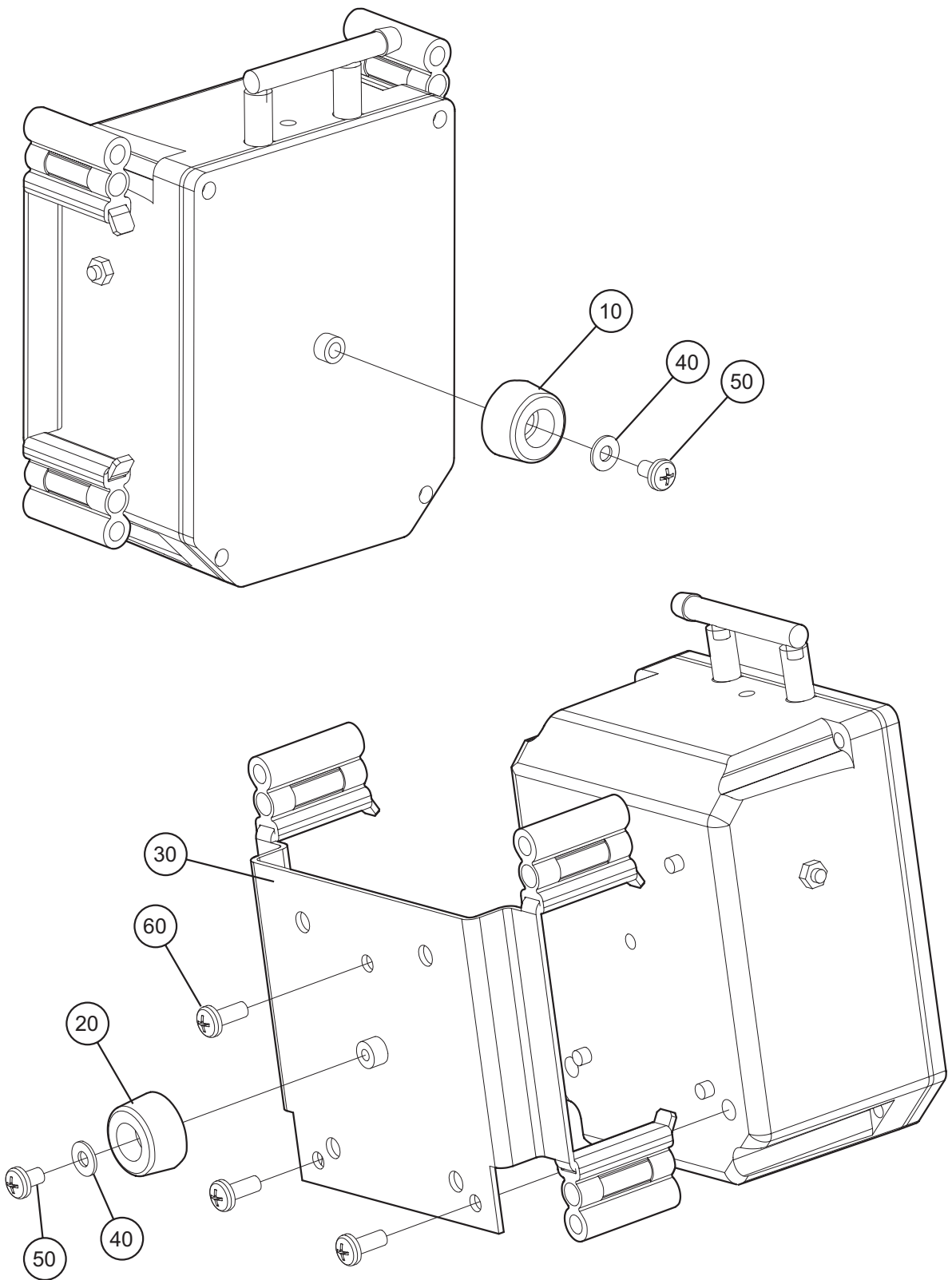

Figure 9 - Replacing Mounting Brackets and Bump Stops

Table 13 - Compressor Mounting Brackets and Bump Stops Part List

Item	Part Number	Description	Qty
10	165310	Upper Bump Stop	1
20	165310	Lower Bump Stop	1
30	500124	Compressor Mounting Bracket (New Style)	1
	N/A	Compressor Mounting Bracket (Old Style)	1
40	FAS160	Washer M4 Plain	2
50	FAS051	Screw Pan Head Pozi M4 x 6 mm	2
60	FAS095	Screw Pan Head Pozi M4 x 10 mm	3

18 Removing the Compressor Mounting Bracket

18.1 Remove the compressor/AV bracket assembly from the pump case and disassemble AV mounts as described on Page 13, Section 14 (new style AV mounts) or Page 15, Section 16 (old style AV mounts. Section 16.4 should be omitted if old style AV mounts are not to be replaced.

Note : Figure 7 illustrates the new style AV mount system. Compressor mounting bracket to compressor assembly methods are the same for both old and new style AV mount systems.

18.2 Remove screw, washer and lower bump stop (Fig 9, Items 50, 40, 20) from the compressor mounting bracket (Fig 9, Item 30).

18.3 Remove three screws (Fig 9, Item 60) and detach the mounting bracket from the compressor.

19 Installing the Compressor Mounting Bracket

19.1 Fit replacement mounting bracket (Fig 9, Item 30) same type (if required) to the compressor. Ensure that the four pegs are correctly located and secure the mounting bracket to the compressor with three screws (Fig 9, Item 60).

19.2 Fit the screw, washer and lower bump stop (Fig 9, Items 50, 40, 20) to the mounting bracket.

19.3 Assemble AV mounts and fit the compressor/AV bracket assembly into the pump case as described in Section 15 (new style AV mounts) or Section 17 (old style AV mounts). Section 17.2 may be omitted.

20 Removing the Compressor Bump Stops

20.1 Remove the compressor/AV bracket assembly from the pump case as described in Section 14.1, 14.2 and 14.3 (new style AV mounts) or Section 16.1, 16.2 and 16.3 (old style AV mounts).

Note : Figure 7 illustrates the new style AV mount system. Bump stop to compressor and bump stop to compressor mounting bracket assembly methods are the same for both old and new style AV mount systems.

20.2 Remove screw, washer and upper bump stop (Fig 9, Items 50, 40, 10) from the compressor lid.

- 20.3 Remove screw, washer and lower bump stop (Fig 9, Items 50, 40, 20) from the compressor mounting bracket.

21 Installing the Compressor Bump Stops

- 21.1 Fit screw, washer and replacement upper bump stop (Fig 9, Items 50, 40, 10) to the compressor lid.
- 21.2 Fit screw, washer and replacement lower bump stop (Fig 9, Items 50, 40, 10) to the compressor mounting bracket.
- 21.3 Refit the compressor/AV bracket assembly to the pump case as described in Page 13, Section 15.2, 15.3 and 15.4 (new style AV mounts) or Page 15, Section 17.3, 17.4 and 17.5 (old style AV mounts).

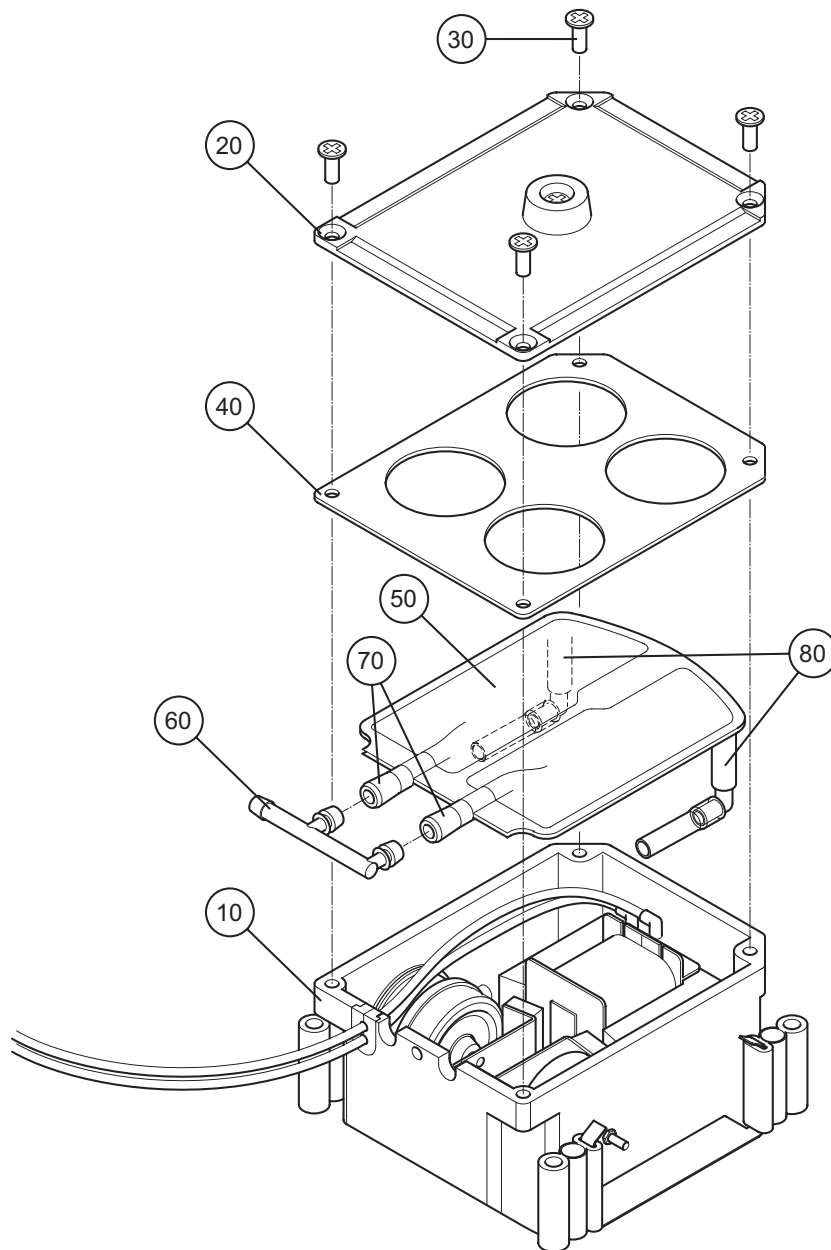

Figure 10 - Compressor Silencer Bag

Table 14 - Compressor Silencer Bag Part List

Item	Part Number	Description	Qty
10	502003	Compressor Assy 230V 50Hz 11K/T	1
	502002	Compressor Assy 110V 60Hz 5K/T (USA)	
	502007	Compressor Assy 100V 50/60Hz 4.5K/T (Japan)	
20	502301	Compressor Lid	1
30	FAS054	Screw Countersunk Pozi M4 x 12 mm	4
40	BP032	Compressor Gasket	1
50	502055	Silencer Bag	1
60	500320	'F' Tube Connector	1
70	N/A	Silencer Bag Outlet Tubes	REF
80	N/A	Silencer Bag Inlet Tubes	REF

22 Replacing the Compressor Silencer Bag

- 22.1 Remove the compressor/AV bracket assembly from the pump case (Refer to Page 13, Section 14.1, 14.2 and 14.3 (new style AV mounts) or Page 15, Section 16.1, 16.2 and 16.3 (old style AV mounts)).
- 22.2 Remove four screws (Fig 10, Item 30) and carefully lift off the compressor lid (Fig 10, Item 20) and gasket (Fig 10, Item 40) from the compressor assembly (Fig 10, Item 10). Discard the gasket.
- 22.3 Disconnect the outlet tubes (Fig 10, Item 70) of the silencer bag (Fig 10, Item 50) from the 'F' tube connector (Fig 10, Item 60).
- 22.4 Disconnect the inlet tubes (Fig 10, Item 80) of the silencer bag from the valve bodies.
- 22.5 Fit a new silencer bag and gasket, then replace the compressor lid by reversing operations detailed in Section 22.4, 22.3 and 22.2.
- 22.6 Refit the compressor/AV bracket assembly to the pump case (Refer to Page 13, Section 15.2, 15.3 and 15.4 (new style AV mounts) or Page 15, Section 17.3, 17.4 and 17.5 (old style AV mounts)).

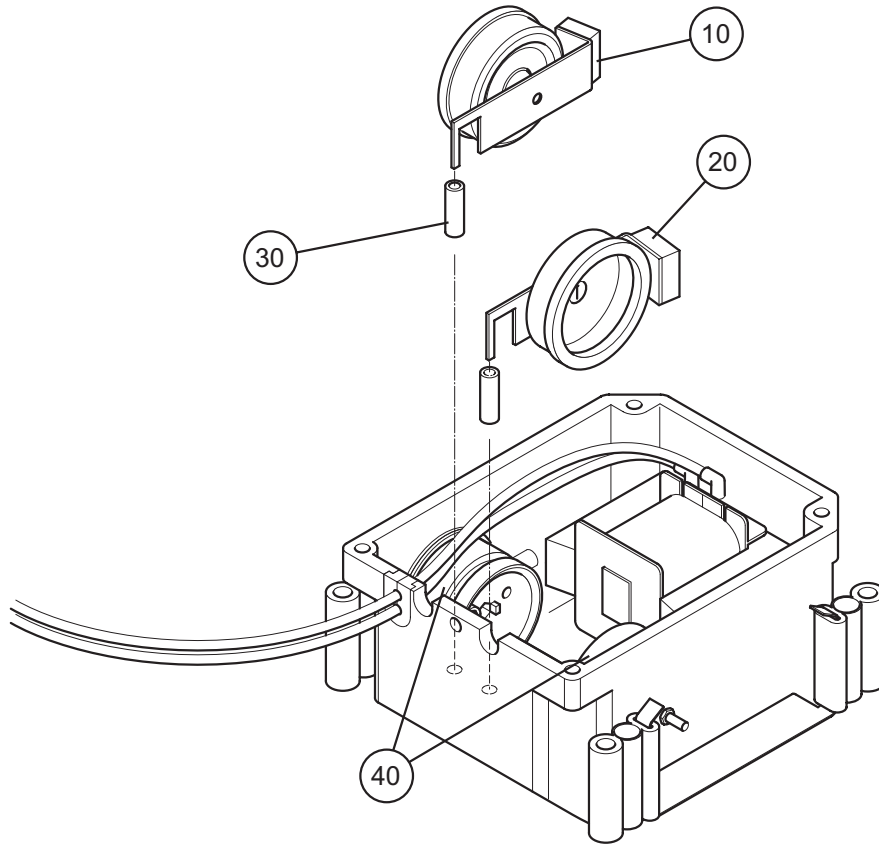

Figure 11 - Bellows Armature Assembly and Pivots

Table 15- Bellows Armature Assembly Part List

Item	Part Number	Description	Qty
10	502054	Bellows Armature Assembly Left-Hand 230V 50Hz	1
	BP215	Bellows Armature Assembly Left-Hand 110V 60Hz	1
20	502053	Bellows Armature Assembly Right-Hand 230V 50Hz	1
	BP214	Bellows Armature Assembly Right-Hand 110V 60Hz	1
30	BP043	Armature Pivot	2
40	BP554	Valve Body	2

23 Replacing the Bellows Armature Assemblies and Pivots

- 23.1 Remove/disassemble the compressor/AV bracket assembly and remove the silencer bag (Refer to Page 19, Section 22.1, 22.2, 22.3 and 22.4).
- 23.2 Using long nosed pliers, extract the armature blade, part of bellows armature assembly (Fig 11, Item 10 or 20) from the armature pivot (Fig 11, Item 30)
- 23.3 Unclip the bellows, part of bellows armature assembly from the valve body (Fig 11, Item 40) and lift the bellows armature assembly clear of the compressor.
- 23.4 Repeat 23.2 and 23.3 as required to remove the other bellows armature assembly.
- 23.5 Discard the old bellows armature assembly and fit a replacement of the same type by reversing the actions carried out in Section 23.3 and 23.2.
- 23.6 Fit a new silencer bag and gasket, then replace the compressor lid (Refer to Page 19 and reverse the operations carried out in Section 22.4, 22.3 and 22.2).
- 23.7 Refit the compressor/AV bracket assembly to the pump case (Refer to Page 13, Section 15.2, 15.3 and 15.4 (new style AV mounts) or Page 15, Section 17.3, 17.4 and 17.5 (old style AV mounts)).
- 23.8 Test the assembly. Note, in order to achieve flow/pressure performance, the new bellows may have to be heated with a hot air gun whilst operating. This anneals the bellows permanently and alters the pressure/flow characteristics.

Caution: The bellows will be damaged if overheated.

24 Replacing the Compressor Armature Pivots

- 24.1 Remove/disassemble the compressor/AV bracket assembly and remove the silencer bag (Refer to Page 19, Section 22.1, 22.2, 22.3 and 22.4).
- 24.2 Extract the armature blade from the pivot (Refer to Section 23.2).
- 24.3 Use a sharp, pointed tool and carefully extract the pivot (Fig 11, Item 30) from the hole in the compressor casing.
- 24.4 Discard old armature pivots and replace with same type. Carefully insert the new pivot into the compressor casing using a small screwdriver to ensure the slot in the pivot is aligned to accept the armature blade.
- 24.5 Fit the armature blade to the pivot reversing the actions carried out in Section 23.2.
- 24.6 Fit a new silencer bag and gasket, then replace the compressor lid (Refer to Page 19 and reverse the operations carried out in Section 22.4, 22.3 and 22.2).
- 24.7 Refit the compressor/AV bracket assembly to the pump case (Refer to Page 13, Section 15.2, 15.3 and 15.4 (new style AV mounts) or Page 15, Section 17.3, 17.4 and 17.5 (old style AV mounts)).

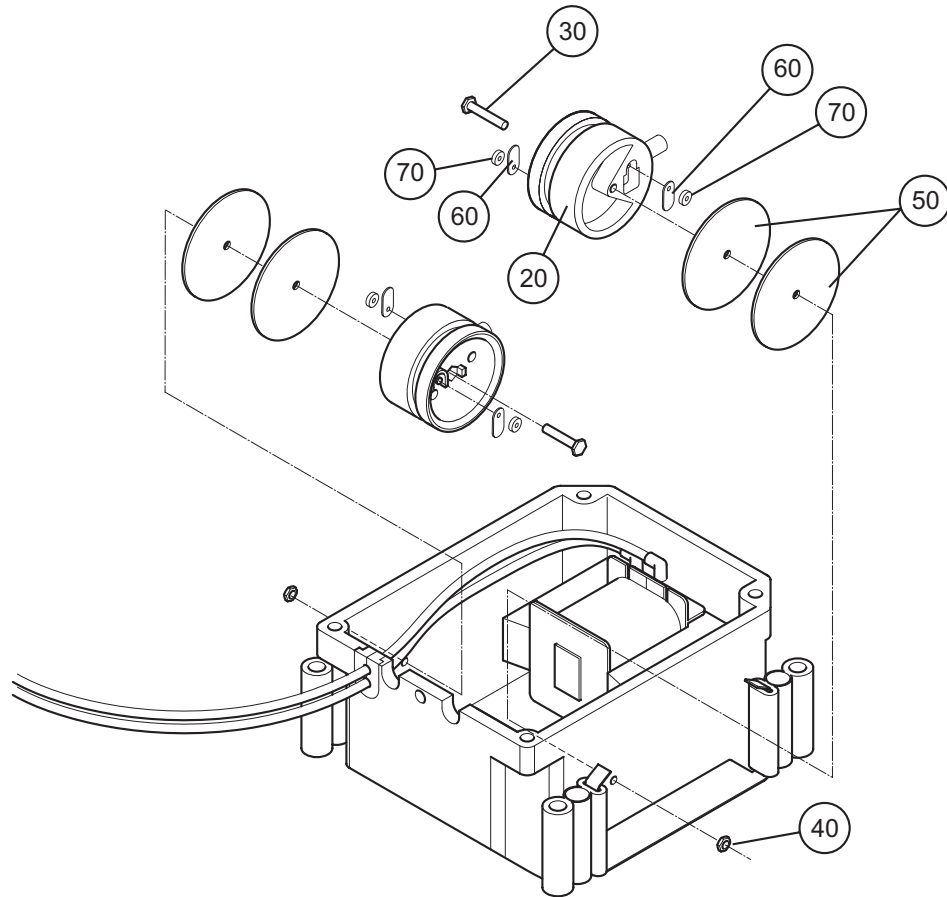

Figure 12 - Compressor Valve Bodies

Table 16 - Compressor Valve Bodies Part List

Item	Part Number	Description	Qty
10	BP554	Valve Body Assy, Blue (Each valve body contains items 20 to 70)	2
20	BP351	Valve Body	1
30	FAS027	Screw, Hex Head 4BA x 3/4	1
40	FAS013	4BA Full Nut	1
50	BP039	Valve Body Washer	2
60	BP037	Valve Flap	2
70	BP038	Valve Flap Securing Pad	2

25 Replacing the Compressor Valve Bodies

- 25.1 Remove/disassemble the compressor/AV bracket assembly and remove the silencer bag (Refer to Page 19, Section 22.1, 22.2, 22.3 and 22.4).
- 25.2 Unclip the bellows, part of bellows armature assembly from the valve body (Refer to Page 20, Fig 11, Items 10 or 20 and 40).
- 25.3 Unscrew and remove the securing nut (Fig12, Item 40) on the side of the compressor housing.
- 25.4 Remove the valve body (Fig 12, Item 20) and Valve body washers (Fig 12, Item 50).
- 25.5 Remove the valve flap securing pads and the valve flaps (Fig 12, Items 70 and 60)
- 25.6 Discard the old valve body and replace with the same type.
- 25.7 Repeat Sections 25.3 to 25.6 as necessary to replace the other valve body.
- 25.8 When replacing the valve flaps and valve flap securing pads, make sure that the valve flap sits flat over the hole in the valve body and the valve securing pad is pushed fully on to the lug.
- 25.9 Position the replacement valve body and secure with screw (Fig 12, Item 20) and nut. Fit the bellows to the valve body.
- 25.10 Fit a new silencer bag and gasket, then replace the compressor lid (Refer to Page 19 and reverse the operations carried out in Section 22.4, 22.3 and 22.2).
- 25.11 Refit the compressor/AV bracket assembly to the pump case (Refer to Page 13, Section 15.2, 15.3 and 15.4 (new style AV mounts) or Page 15, Section 17.3, 17.4 and 17.5 (old style AV mounts)).

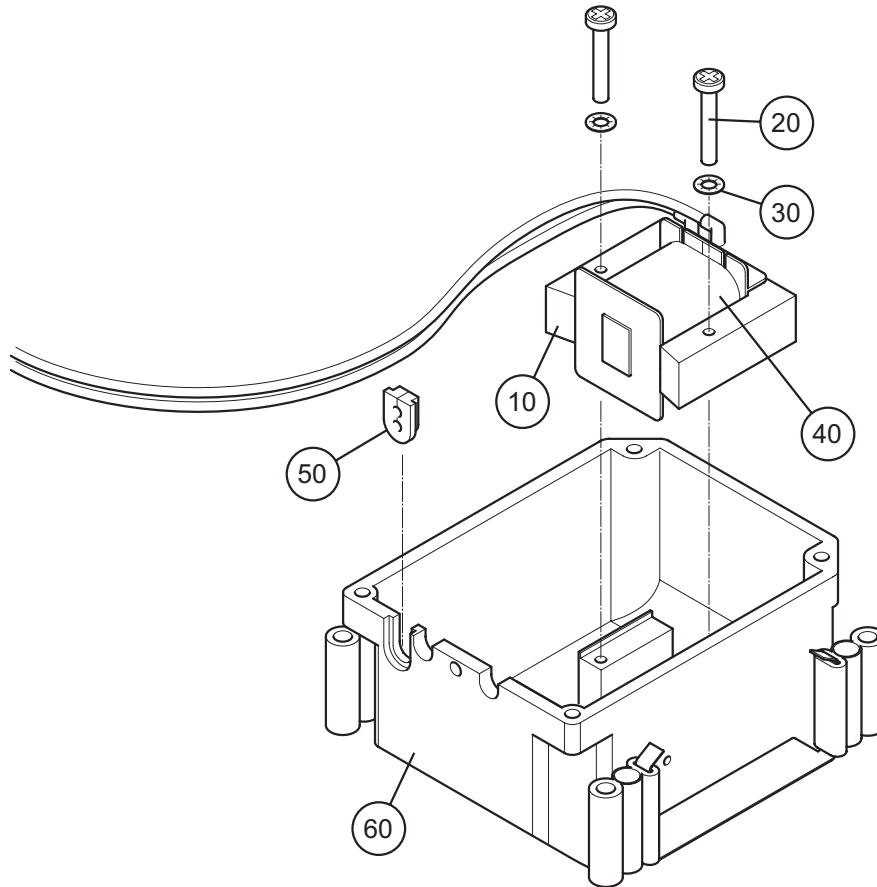

Figure 13 - 'E' Stack and Coil Assembly

Table 17 - 'E' STACK and Coil Assembly Part List

Item	Part Number	Description	Qty
10	BP028	'E' Stack	1
20	FAS048	Pan Head Screw M3 x 25 mm Pozi	2
30	FAS002	Washer - 6BA Anti-Vib.	2
40	502050	Coil Assembly 230V 50Hz (black/white leads)	1
	502062	Coil Assembly 110V 60Hz (grey leads)	1
	BP275	Coil Assembly 100V 50/60Hz (blue leads)	1
50	165303	Grommet	1
60	502304	Compressor Case	1

26 Replacing the 'E' Stack Assembly

Note : After doing work in either Section 26 or 27 the pressure/flow characteristics can be altered by moving the coil assembly/'E' stack nearer or further from the armature magnets. This can be done by adjusting screws (Fig 13, Item 20). Ensure the screws are tightened afterwards.

- 26.1 Remove/disassemble the compressor/AV bracket assembly and remove the silencer bag (Refer to Page 19, Section 22.1, 22.2, 22.3 and 22.4).
- 26.2 Unscrew and remove the two screws and anti-vibration washers (Fig 13, Items 20 and 30) which secure the 'E' stack/coil assembly (Fig 13, Items 10 and 40).
- 26.3 Withdraw the 'E' stack/coil assembly from the compressor case as far as the electrical wires will allow.
- 26.4 Carefully remove the 'E' stack from the coil assembly.
- 26.5 Replace the 'E' stack by reversing the operations carried out in Section 26.4, 26.3 and 26.2.
- 26.6 Fit a new silencer bag and gasket, then replace the compressor lid (Refer to Page 19 and reverse the operations carried out in Section 22.4, 22.3 and 22.2).
- 26.7 Refit the compressor/AV bracket assembly to the pump case (Refer to Page 13, Section 15.2, 15.3 and 15.4 (new style AV mounts) or Page 15, Section 17.3, 17.4 and 17.5 (old style AV mounts)).

27 Replacing the Coil Assembly

- 27.1 Remove/disassemble the compressor/AV bracket assembly and remove the silencer bag (Refer to Page 19, Section 22.1, 22.2, 22.3 and 22.4).
- 27.2 Remove the 'E' stack/coil assembly as described in Section 26.2 and 26.3.
- 27.3 Disconnect the compressor electrical wires from the terminal block. Carefully cut the cable ties from the pneumatic tubing/cable loom as required.
- 27.4 Feed the compressor electrical wires through the compressor case cable grommet (Fig 13, Item 50).
- 27.5 Remove the 'E' stack/coil assembly from the compressor case (Fig 13, Item 60) and carefully separate the coil from the 'E' stack.
- 27.6 Replace the coil assembly by reversing the operations carried out in Section 27.5, 27.4, 27.3 and 27.2; fit new cable ties where required.
- 27.7 Fit a new silencer bag and gasket, then replace the compressor lid (Refer to Page 19 and reverse the operations carried out in Section 22.4, 22.3 and 22.2).
- 27.8 Refit the compressor/AV bracket assembly to the pump case (Refer to Page 13, Section 15.2, 15.3 and 15.4 (new style AV mounts) or Page 15, Section 17.3, 17.4 and 17.5 (old style AV mounts)).

28 Replacing the Compressor Assembly

- 28.1 Disconnect the compressor electrical wires as described in Section 27.3.

- 28.2 Remove the compressor air inlet filter and clip from the 'F' tube connector, then disconnect the 'F' tube connector from the silencer bag outlet tubes (Refer to Page 11, Section 12.1, 12.2, 12.3 and 12.4).
- 28.3 Remove the compressor/AV bracket assembly from the pump case (Refer to Page 13, Section 14.1, 14.2 and 14.3 (new style AV mounts) or Page 15, Section 16.1, 16.2 and 16.3 (old style AV mounts)).
- 28.4 Remove the compressor mounting bracket (Refer to Page 17, Section 18).
- 28.5 Fit a replacement compressor assembly by reversing the actions detailed above.

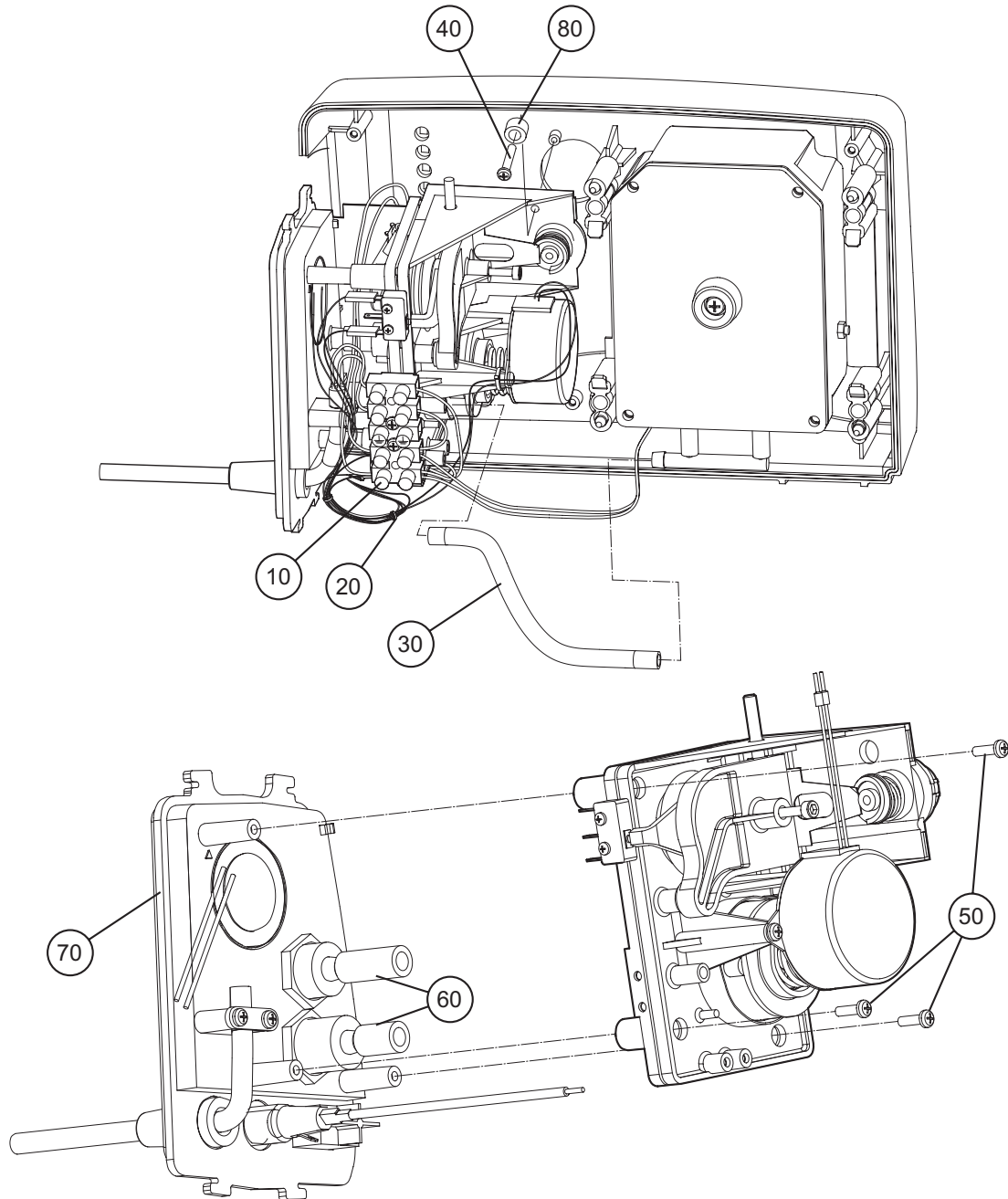

Figure 14 - Pressure Control Module

Table 18 - Pressure Control Module Part List

Item	Part Number	Description	Qty
10	500347	Terminal Block 5 way	1
20	BP196	Cable Tie	2
30	500362	Tube Sil ID 3/16" 135 mm ± 5 mm LG	1
40	FAS145	Screw 3 Dia. x 8 mm Pozi Pan Head PT	1
50	FAS223	Screw 3 Dia. x 10 mm Pozi Pan Head PT	3
60	500315	Panel Side Colder	1
70	500328	Panel Side Push On	1
80	151309	Fixing Cap	1

29 Replacing the Pressure Control Module

- 29.1 Remove the pressure control knob as described in Page 3, Section 2.
- 29.2 Remove the rear case assembly as described in Page 5, Section 6.
- 29.3 Remove the compressor wires (Fig 14, Item 10) from the terminal block (terminals 3 and 4). This also releases two switch wires.
- 29.4 Carefully cut the cables ties from the wiring loom as required (Fig 14, Item 20).
- 29.5 Remove the tube (Fig 14, Item 30) between the pressure control module and the 'F' connector.
- 29.6 Remove the module securing screw (Fig 14, Item 40) and the fixing cap (Fig 14, Item 80).
- 29.7 Carefully lift the module with the side panel attached from the pump case.
- 29.8 Disconnect the fuse wire from the terminal block (terminal 6) and disconnect the adjacent switch wire (terminal 5) (Fig 14, Item 10).
- 29.9 Disconnect the mains/power lead wires from the terminal block (terminals L and N) (Fig 14, Item 10).
- 29.10 Remove three screws (Fig 14, Item 50) and detach (pull off the pressure control module from the side panel assembly (Fig 14, Item 70).
- 29.11 Replacement is the reversal of the above procedures. Refer to the wiring diagram (Chap. 4, Fig 23 (electronic) or 24 (mechanical)) when reconnecting the wires to the terminal block.

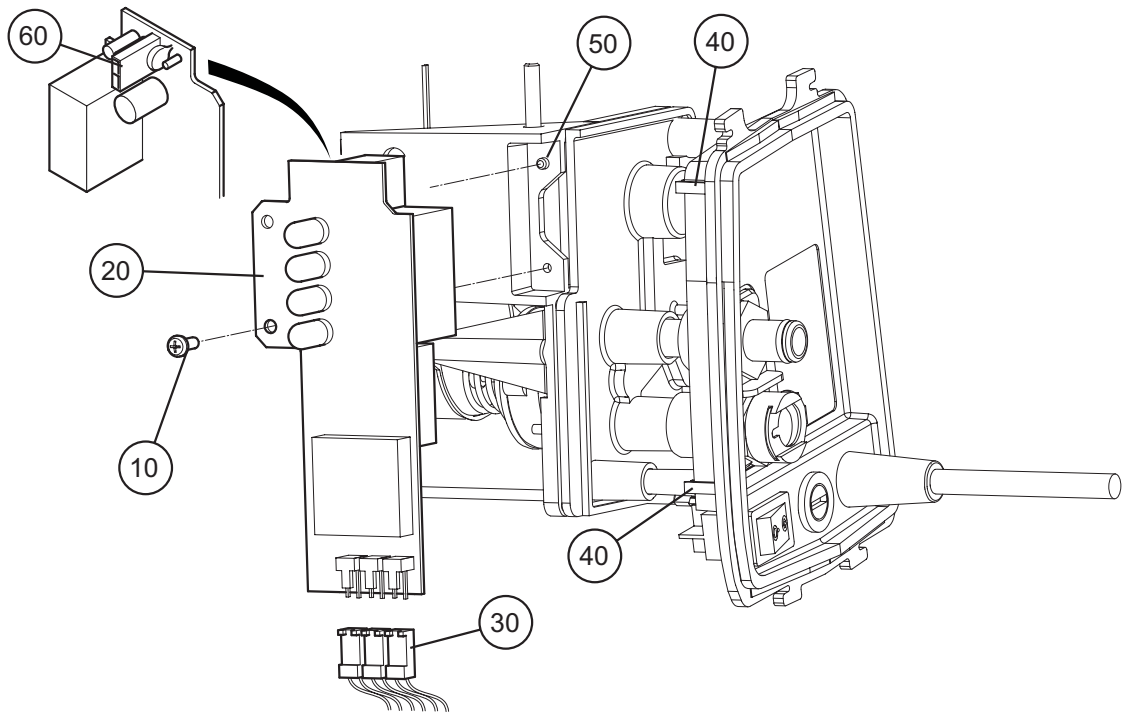

Figure 15 - Removing the Alarm Monitoring PCB

Table 19 - Removing the Alarm Monitoring PCB Part List

Item	Part Number	Description	Qty
10	FAS083	Screw No. 6 x 5/16" Pozi Pan Head PT	1
20	500346	PCB Alarm Monitoring 230 V	1
	500345	PCB Alarm Monitoring 100/120 V	1
30	N/A	Signal Connectors	REF
40	N/A	Side Panel Slotted Mounts	REF
50	N/A	Lug	REF
60	N/A	PCB Power Wires Socket	REF

30 Replacing the Alarm Monitoring PCB

CAUTION : *Electrostatic discharge can seriously damage the alarm monitoring PCB. Prior to replacing or handling, adequate earth/grounding precautions must be taken.*

Notes : 1 It is not necessary to remove the side panel in order to replace the alarm monitoring PCB.
2 The alarm monitoring PCB is only applicable to electronic versions of the mini pump.

- 30.1 Remove the pressure control module as described in Page 27, Section 29.1 to 29.7.
- 30.2 Disconnect PCB power wires (Fig 15, Item 60) from PCB.
- 30.3 Disconnect the three signal connectors from the PCB (Fig 15, Item 30).
- 30.4 Remove the PCB securing screw (Fig 15, Item 10) and withdraw the PCB (Fig 15, Item 20).
- 30.5 Replacement is the reverse procedure to removal. Ensure that the PCB is seated in the two slotted mounts of the side panel (Fig 15, Item 40) and the lug (Fig 15, Item 50) on the pressure control module.

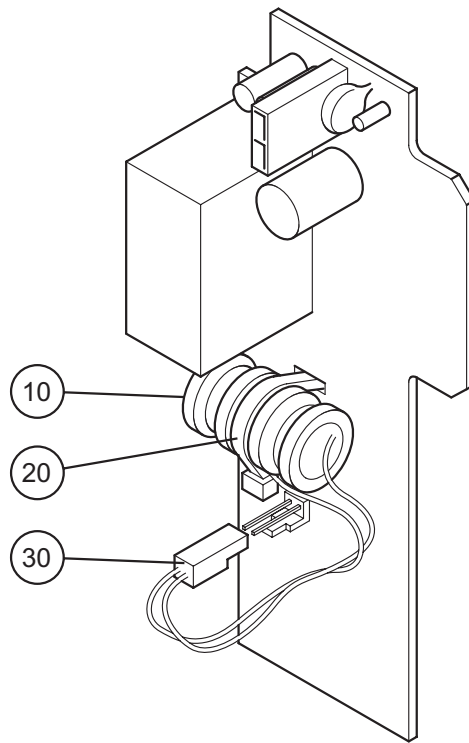

Figure 16 - Replacing the Power Failure Alarm Battery

Table 20 - Battery (Power Failure Alarm) Part List

Item	Part Number	Description	Qty
10	151457	Battery	1
20	N/A	Cable Tie	1
30	N/A	Battery Plug to PCB	1

31 Changing the Battery

Caution : *Electrostatic discharge can seriously damage the alarm monitoring PCB. Prior to replacing or handling, adequate earth/grounding precautions must be taken.*

Notes : 1 *It is not necessary to remove the side panel in order to change the battery.*

2 *The battery (power failure alarm) is only applicable to electronic versions of the mini pump.*

31.1 Remove the PCB (Refer to Page 29, Section 30,).

31.2 Remove the battery plug (Fig 16, Item 30) from the PCB.

31.3 Cut and remove the cable tie (Fig 16, Item 20) and remove the battery (Fig 16, Item 10).

31.4 Replacement is the reverse procedure to removal.

Note : *The cable tie must be renewed/replaced when changing the battery.*

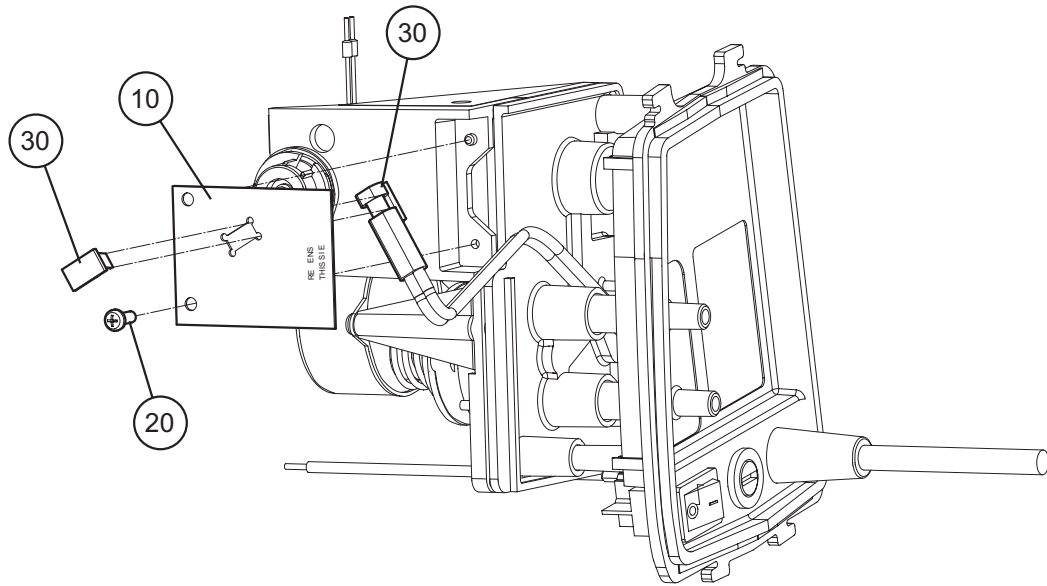

Figure 17 - Replacing the Neon Indicator Light

Table 21 - Neon Indicator Part List

Item	Part Number	Description	Qty
10	FAS083	Screw No. 6 x 5/16" Pozi Pan Head PT	1
20	500324	Plate Neon Mounting	1
30	500373	Neon Assembly Red 230 V	1
	500371	Neon Assembly Red 110 V	

32 Replacing the Neon Indicator Light

Note : The neon indicator light is only applicable to the mechanical versions of the pump. The electronic version of the pump has two red indicators, a green indicator and a yellow indicator. These are wired directly into the PCB and are replaced only by exchanging the complete PCB.

- 32.1 Disconnect the indicator lead from the terminal block (terminal 2) (Fig 14, Item 10).
- 32.2 Disconnect the indicator lead from the Micro switch (Fig 18, Item 10).
- 32.3 Release the screw (Fig 17, Item 20) attaching the neon mounting plate (Fig 17, Item 10) and remove the neon (Fig 17, Item 30) and mounting plate assembly.
- 32.4 Note the orientation of the components, unclip the neon (Fig 17, Item 30) from the lens and push the lens out of the mounting plate.
- 32.5 Replacement is the reverse procedure of the above. Ensure the correct orientation of components. Connect the wires to the terminal block and the Micro switch in accordance with the wiring diagram for the mechanical version of the pump unit (Chap. 4, Fig 25).

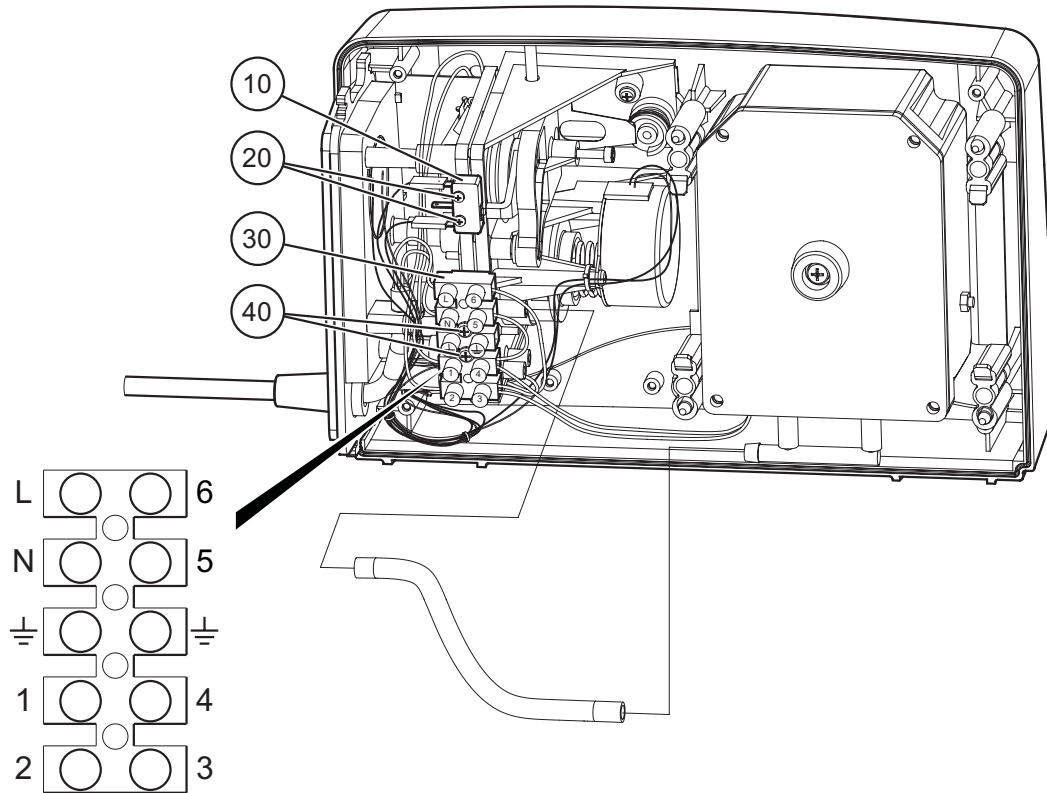

Figure 18 - Replacing the Micro switch and Terminal Block

Table 22 - Micro switch and Terminal Block Part List

Item	Part Number	Description	Qty
10	500338	Micro switch Sub Min 230 V/0.1A	1
20	FAS224	Screw 2.2 Dia. x 14 mm Pozi Pan Head PT	2
30	500347	Terminal Block 5 Way	1
40	FAS225	Screw 3 Dia. x 16 mm Pozi Pan Head PT	2

33 Replacing the Microswitch

Note : It is not necessary to remove the pressure control module from the pump case.

- 33.1 Pull off connectors from the Micro switch terminals 1 and 3 (Fig 18, Item 10).
- 33.2 Release two screws (Fig 18, Item 20) and remove the Micro switch from the pressure control module.
- 33.3 Replacement is the reverse of the above procedure.

34 Replacing the Terminal Block

Note : It is not necessary to remove the pressure control module from the pump case.

- 34.1 Disconnect all wires from the terminal block (Fig 18, Item 30).
- 34.2 Release two securing screws (Fig 18, Item 40) and remove the terminal block from the pressure control module.
- 34.3 Replacement is the reversal of the above procedure. Refer to the wiring diagram (Chap. 4, Fig 24) when reconnecting the wires for the electronic version of the pump and wiring diagram (Chap. 4, Fig 25) when reconnecting the wires for the mechanical version of the pump.

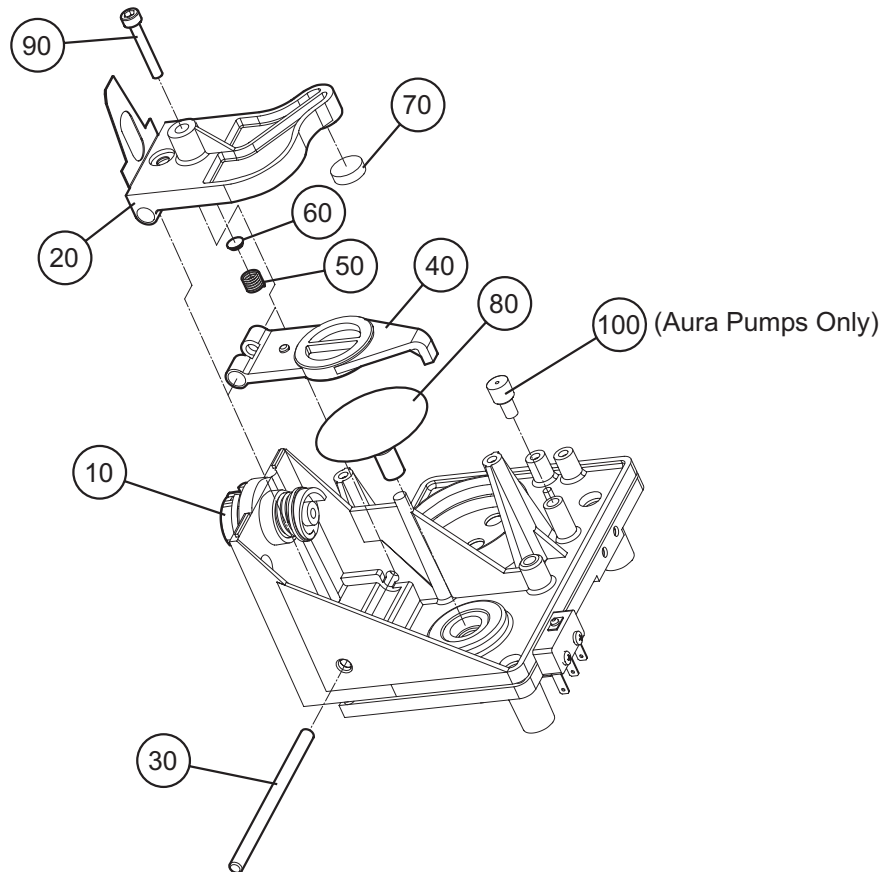

Figure 19 - Pressure Control Flaps, Air Bag, Control Knob Cam and Arbour

Table 23 - Pressure Control Flaps, Air Bag, Control Knob Cam and Arbour Part List

Item	Part Number	Description	Qty
10	500304	Knob Control Arbour	1
20	500312	Upper Pressure Control Flap	1
30	500318	Pivot Pin, Pressure Control	1
40	500303	Lower Pressure Control Flap	1
50	500341	Spring 0,024" Diameter	1
60	151339	Pressure Control Disc	1
70	PRE022	Rubber Valve Disc	1
80	500103	Bag Pressure with Restrictor Assembly	1
90	500355	Screw M3 x16 mm Socket Cap Hd Black	1
100	403306	Restrictor (Aura Pumps Only)	1

35 Replacing the Pressure Control Flaps and Air Bag

- 35.1 Turn the control knob around fully counter-clockwise (Fig 19, Item 10). Hold the upper pressure control flap (Fig 19, Item 20) in position and withdraw the pivot pin (Fig 19, Item 30). Carefully remove the upper flap and the lower flap (Fig.19, Item 40) together with the low pressure operating spring and brass disc (Fig 19, Items 50 and 60).
- 35.2 Remove and discard the pressure control disc (Fig 19, Item 70) from the upper flap. Replace with new item.
- 35.3 Remove and discard the air bag assembly (Fig 19, Item 80). Replace with a new item. Ensure the air bag is secure by pushing in the centre and rotate it slightly to ensure it is seated.
- 35.4 Ensure that the low pressure adjustment screw (Fig 19, Item 90) is fully disengaged. Carefully locate the brass disc (Fig 19, Item 60), boss uppermost in the rebate in the upper flap. Locate the spring (Fig 19, Item 50) on the disc and position the lower flap (Fig 19, Item 40) against the spring.
- 35.5 Refitting is the reverse of the above procedure. When refitting, hold the group of components together and position them on the pressure control module. Insert the pivot pin (Fig 19, Item 30) to retain the flaps.

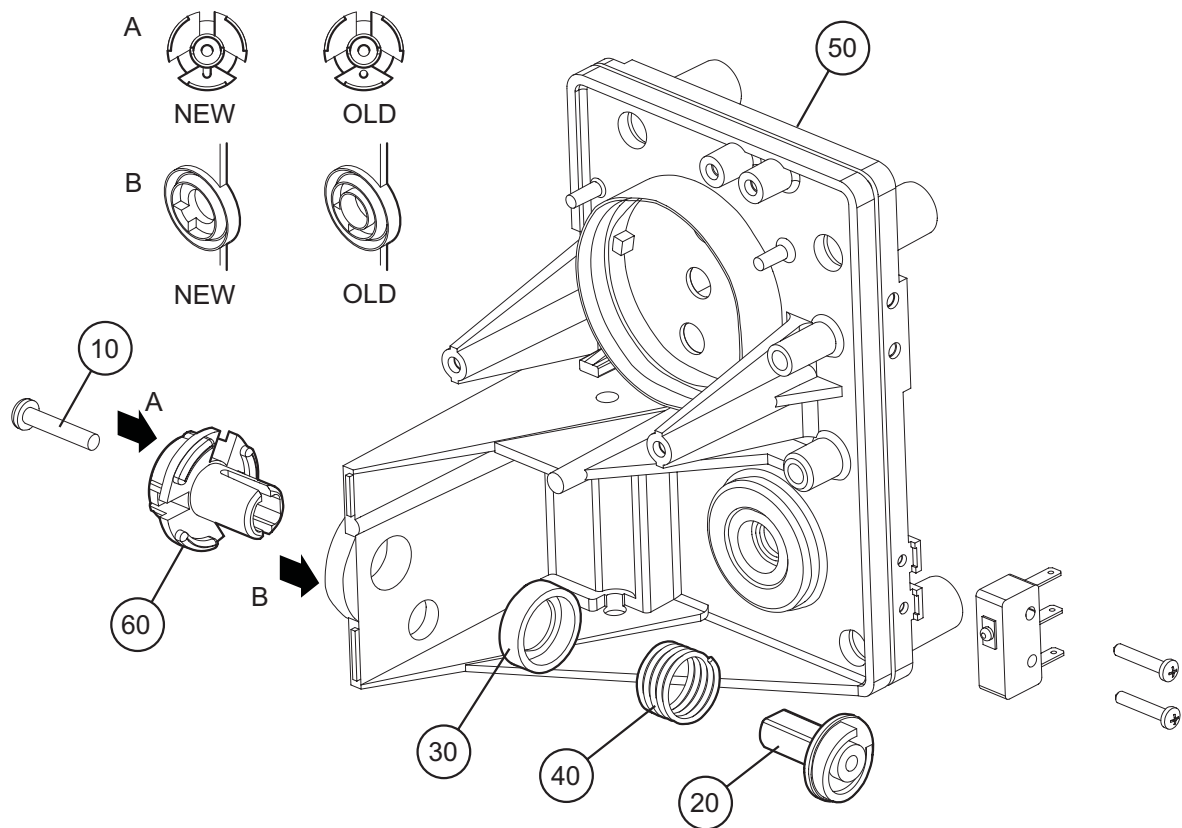

Figure 20 - Control Knob Cam and Arbour

Table 24 - Control Knob Cam and Arbour Part List

Item	Part Number	Description	Qty
10	FAS225	Control Adjustment Screw, 3 Dia x 16 mm Pozi Pan Head PT	1
20	500305	Knob Control Cam	1
30	500411	Cup Arbour Drive Spring	1
40	500339	Spring Comp 1.07 Diameter	1
50	500349	Pressure Assembly Module	1
60	500304	Knob Control Arbour	1

36 Replacing the Pressure Control Assembly

*Note : It is **not** necessary to remove the side panel assembly from the pressure control module.*

- 36.1 Remove the pressure control module from the pump case as described in Section 29.
- 36.2 Remove the pressure control flaps as described in Section 35.
- 36.3 Release the control adjustment screw on the control knob arbour (Fig 20, Item 10).
- 36.4 Carefully remove the arbour, cam, spring cup and spring (Fig 20, Items 20, 30 and 40).
- 36.5 Renew/replace components with the same type.

Note : Early versions may have a nylon washer in lieu of the spring cup. Discard the washer and replace with the cup.

- 36.6 Replacement is the reverse of the above procedure. Refit the pressure control flaps as described in Section 35.

Note : The new control knob arbour will NOT fit the old pressure assembly module because of the moulded wall on the old pressure assembly module. The old control knob arbour will fit both.

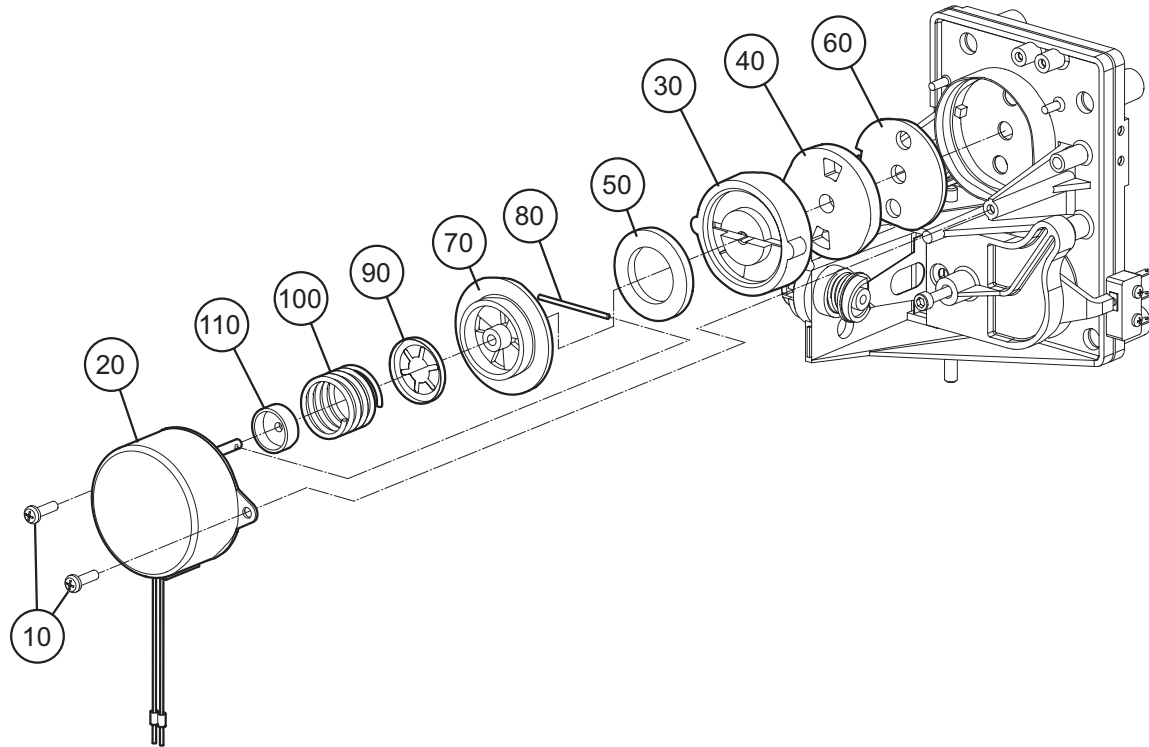

Figure 21 - Synchronous Motor (Gearbox), Rotor/Stator Assembly

Table 25 - Synchronous Motor (Gearbox), Rotor/Stator Assembly Part List

Item	Part Number	Description	Qty
10	FAS223	Screw 3 Dia x 10 mm Pozi Pan Head	2
20	500097	Gearbox 240V and Ferrule Assembly	1
	500098	Gearbox 120V and Ferrule Assembly	1
	500099	Gearbox 100V and Ferrule Assembly	1
	151409	Motor Gearbox 100V, 50 Hz, 1/10 RPM	1
30	500308	Rotor Module	1
40	500307	Stator Module	1
50	500332	Felt Rotor Silencer	1

Table 25 - Synchronous Motor (Gearbox), Rotor/Stator Assembly Part List (continued)

Item	Part Number	Description	Qty
60	500319	Stator Gasket	1
	500418	Stator Gasket (Restricted)	1
70	500356	Rotor Drive Cup	1
80	500322	Pin Rotor Drive	1
90	500354	Washer Starlock O/D 21 mm	1
100	500358	Spring Comp 1.6 Diameter FL 22.36	1
110	TIM017	Oil Seal Cap	1

37 Replacing the Synchronous Motor (Gearbox), Rotor Stator Assembly

*Note : It is **not** necessary to remove the side panel assembly from the pressure control module.*

- 37.1 Remove the pressure control module from the pump case as described in Section 29.
- 37.2 Remove any relevant cable ties.
- 37.3 Identify the synchronous motor electrical lead from the terminal block (terminals 1 and 2) (Fig 18, Item 30). remove the relevant cable ties and release the synchronous motor electrical lead.
- 37.4 Remove the two screws securing the gearbox motor (Fig 21, Item 10).
- 37.5 Carefully remove the synchronous motor, rotor and stator (Fig 21, Items 20, 30 and 40) from the pressure control module. Remove the felt rotor silencer (Fig 21, Item 50) from the rotor. Remove the stator gasket (Fig 21, Item 60) from the pressure assembly module.
- 37.6 Depress the motor drive cup (Fig 21, Item 70) toward the motor and remove the drive shaft pin (Fig 21, Item 80).
- 37.7 Carefully remove the rotor drive cup, star washer (Fig 21, Item 90), spring (Fig 21, Item 100) and oil seal cap (Fig 21, Item 110) from the motor.
- 37.8 Replace any faulty parts with same type.
- 37.9 Discard the stator gasket and replace with a new one before reassembly.
- 37.10 Replacement is the reverse of the above procedure. Ensure that the stator is correctly located in the key and cables are secured with relevant cable ties.

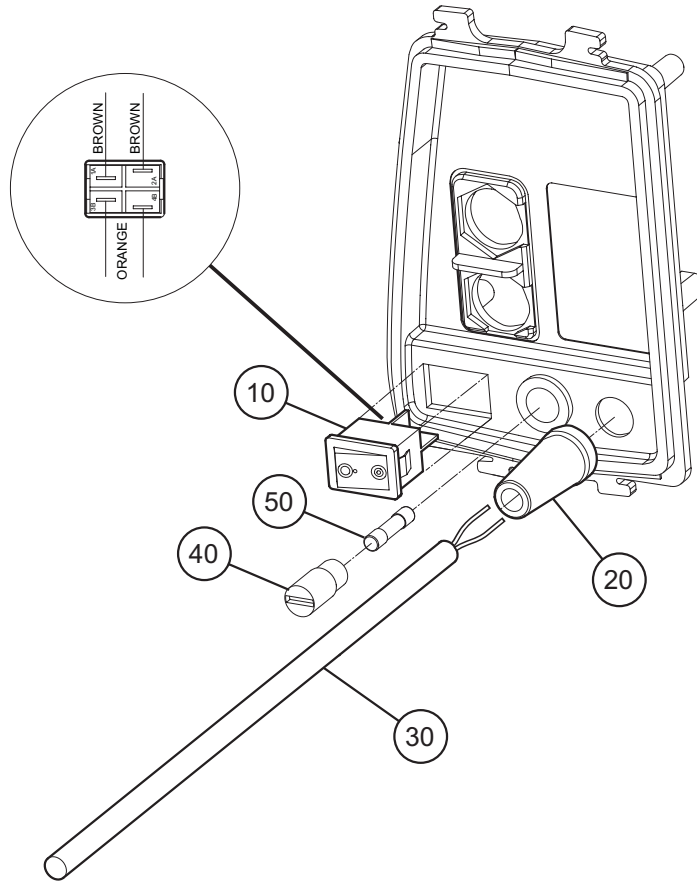

Figure 22 - Replacement of the Side Panel On/Off Switch

Table 26 - Side Panel On/Off Switch, Mains/Power Lead and Fuses Part List

Item	Part Number	Description	Qty
10	500351	Switch Mains/Power Rocker 230 V Black (All electronic pumps)	1
	500343	Switch Mains/Power Rocker 230 V Green (Illuminated)	1
	500359	Switch Mains/Power Rocker 110 V Green (Illuminated)	1
20	198315	Grommet	1
30	BP532	Cordset Standard Moulded UK (Cable)	1
	CAS041	Mains/Power Cable - European "Shuko" Socket	1
	BP087	Mains/Power Cable - USA 2 pin	1
	CAS020	Mains/Power Cable - Japan 2 pin	1
	BP171	Mains/Power Cable - Australia	1
40	500344	Fuse Holder	1
50	CAS011	Fuselink 20 x 5 mm 500 mA QB	1

38 Replacing the Side Panel Mains/Power On/Off Switch

- 38.1 Remove the pressure control module and remove the side panel as described in Section 29.
- 38.2 Pull off the electrical connections from the On/Off switch (Fig 22, Item 10).
- 38.3 Squeeze together the retaining flanges located on either side of the switch body and push the switch through the side panel.
- 38.4 Replace the switch with same type. Ensure correct orientation of the switch (symbol ● nearest the fuse). Ensure that the retaining flanges snap into position. Refer to the wiring diagram (Chap. 4, Fig 23) when reconnecting the electrical wires for the electronic version of the pump and (Chap. 4, Fig 24) when connecting the electrical wires for the mechanical version of the pump.

39 Replacing the Side Panel Mains/Power Lead

- 39.1 Remove the pressure control module, and remove the side panel as described in Section 29.
- 39.2 Carefully withdraw the mains/power lead (Fig 22, Item 30) through the mains lead/power cord grommet.
- 39.3 Carefully withdraw the mains/power lead grommet (Fig 22, Item 20) through the side panel.
- 39.4 Replace the lead with the same part number. Replacement is the reverse of the above procedure. Ensure adequate cable length so that wires are not strained.

WARNING:

WHEN AN UNSERVICEABLE MAINS/POWER LEAD FITTED WITH A NON-REWIREABLE PLUG IS REMOVED FROM THIS EQUIPMENT, THE LEAD/CORD AND THE PLUG MUST BE DESTROYED AND DISPOSED OF SAFELY. TO AVOID THE DANGER OF ELECTRIC SHOCK THE PLUG MUST NEVER BE INSERTED IN ANY POWER OUTLET.

40 Replacing the Fuses

Note : The side panel assembly is supplied complete with fuse holder fitted. The fuse holder is not a replaceable item.

- 40.1 To replace the pump fuse undo the fuse holder (Fig 22, Item 40) and remove the fuse (Fig 22, Item 50). Replace with fuse of same type.
- 40.2 To replace the mains/power lead plug fuse in moulded plugs use a small bladed electrical screwdriver and carefully lever off the fuse cover on the pin side of the plug. Replace with fuse of same type.

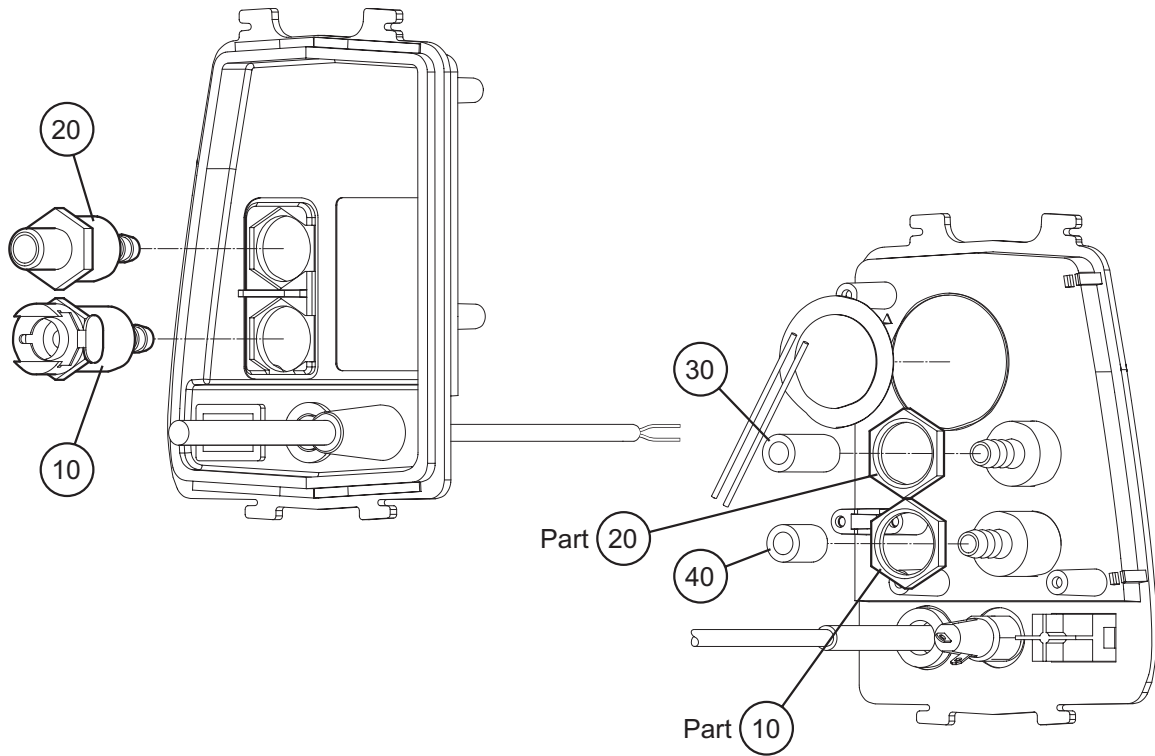

Figure 23 - Snap-lock Connectors

Table 27- Snap-lock Connectors

Item	Part Number	Description	Qty
10	500350	Connector Panel, Female 1/4" Flow	1
20	504316	Connector Panel, Male 1/4" Flow	1
30	500361	Tube Sil Blue ID 6 OD 10 24 LG ± 1	1
40	500360	Tube Sil Blue ID 6 OD 10 15 LG ± 1	1

41 Replacing the Snap-lock Connectors

Note : Older versions have a pump connectors moulded within the side panel and are not replaceable.

- 41.1 Remove pressure control module with side panel (Refer to Section 29.1 to 29.7)
- 41.2 Refer to Fig 15, disconnect the three signal connectors (Fig 15, Item 30) and the power wires from the PCB.
- 41.3 Remove screw (Fig 15, Item 10) and remove the PCB.
- 41.4 Undo locknut and withdraw connector through side panel with tube.
- 41.5 Remove tube from connector.
- 41.6 Replace with the same type. Replacement is the reverse of the above procedure. Ensure that the snap lock release clip on the female (lower) connector is pointing toward the rear of the case. Make sure the locknut is on the pressure module before the connector and tube is inserted.

42 Removing the Front Case

- 42.1 Remove the pressure control knob (Page 3, Section 2).
- 42.2 Disassemble the rear case (Page 5, Section 6).
- 42.3 Remove the screw and the fixing cap (Refer to Fig 14, Items 40 and 80) from the pressure control module.
- 42.4 Remove the pressure control module, together with the side panel, and the compressor from the front case (Fig 2, Item 40).

43 Installing the Front Case

- 43.1 For Aura, AlphaXcell, AlphaTrancell ALT01-09, fit the pin (Fig 2, Item 30) to the new front case.

Note : For Alpharelief, Alphabed, Alphacare and AlphaTrancell ALT10 pumps, the pin is not needed. This allows 270° movement of the Pressure Control Knob.

- 43.2 Fit a front label to the front case (Refer to Table 28 for the correct label set).
- 43.3 Install the pressure control module, together with the side panel, and the compressor in the front case.
- 43.4 Install the fixing cap and the screw (Refer to Fig 14, Items 80 and 40) to the pressure control module.
- 43.5 Assemble the rear case (Page 5, Section 7).
- 43.6 Install the pressure control knob (Page 3, Section 3).
- 43.7 Fit rubber feet to the base of the front case (Fig 4, Item 50).

44 Pump Label Sets

The following table gives the part numbers for the pump label sets:

Table 28 - Pump Label Sets

Part Number	Description	Qty
AlphaXcell Series		
500386	Label set UK - AlphaXcell (ALX01)	1
500387	Label set Germany - AlphaXcell (ALX02)	1
500388	Label set USA - AlphaXcell (ALX03)	1
500389	Label set Euro - AlphaXcell (ALX04)	1
500390	Label set France - AlphaXcell (ALX05)	1
500391	Label set Japan - AlphaXcell (ALX06)	1
500392	Label set Italy - AlphaXcell (ALX017)	1
500393	Label set Australia - AlphaXcell (ALX08)	1
500394	Label set Rest of the World - AlphaXcell (ALX09)	1
500395	Label set Holland - AlphaXcell (ALX10)	1
500472	Label set Rest of the World - AlphaXcell (ALX11)	1
AlphaBed Series		
500397	Label set UK - AlphaBed (ALB01)	1
500398	Label set Euro - AlphaBed (ALB04)	1
500441	Label set Poland - AlphaBed (ALB04 - PL)	1
500399	Label set Australia - AlphaBed (ALB08)	1
500400	Label set Rest of the World - AlphaBed (ALB09)	1
Alpha Trancell Series		
500412	Label set UK - Alpha Trancell (ALT01)	1
500396	Label set Germany - AlphaTrancell (ALT02)	1
500414	Label set Holland - Alpha Trancell (ALT10)	1
500440	Label set Poland - Alpha Trancell (ALT01-PL)	1

Table 28 - Pump Label Sets (continued)

Part Number	Description	Qty
Alpha Relief Series		
500475	Label set UK - Alpha Relief (ALR01)	1
500478	Label set Germany - Alpha Relief (ALR02)	1
500470	Label set USA - Alpha Relief (ALR03)	1
500476	Label set Euro - Alpha Relief (ALR04)	1
AlphaCare Series		
500401	Label set USA - AlphaCare (ALC03)	1
500402	Label set Euro - AlphaCare (ALC04)	1
500473	Label set Japan - AlphaCare (ALC06)	1
Aura Series		
500474	Label set UK - Aura (ALS01)	1
500479	Label set USA - Aura (ALS03)	1
500477	Label set Euro - Aura (ALS04)	1

CHAPTER 4

TROUBLESHOOTING

1 General

This section details some problems which may occur after a long period of use and the appropriate procedures to correct them.

The Alpha Relief, Aura and AlphaXcell (electronic) pump units are fitted with a visual and audible alarm for **LOW PRESSURE** and **POWERFAIL** alarm conditions. The alarm for the AlphaBed, Care and Trancell (mechanical) pump units are limited to a visual red **LOW PRESSURE** (!) lamp indicator. The alarm automatically resets when the operating pressure is regained. See Table 4 for details of the each product's visual indicators.

Table 29 gives a quick reference to common problems, possible causes and actions. Refer to the table first when carrying out troubleshooting on a pump.

Table 29 - Troubleshooting

Problem	Possible Cause	Action
Mattress/Seat not Inflating. <i>Applicable to all pumps.</i>	<ol style="list-style-type: none"> 1. CPR not inserted (mattress only). 2. Tubes kinked. 3. Pump not switched on. 4. No pump output. 5. Tubes not correctly fitted. 	<p>Check CPR (See Mattress Service Manual SER0005).</p> <p>Check.</p> <p>Check.</p> <p>Check. See 'Pump not operating' below.</p> <p>Check.</p>
Low pressure alarm. <i>Applicable to all pumps.</i>	<ol style="list-style-type: none"> 1. CPR not inserted (mattress only). 2. Tubes not correctly fitted. 3. Leakage. 	<p>Check CPR (See Mattress Service Manual SER0005).</p> <p>Check.</p> <p>Check (See Mattress Service Manual SER0005).</p>
Wait indicator does not go out not allowing the system to pressurize. <i>Applicable to:</i> <i>ALR 01-10</i> <i>ALX 01-10</i>	<ol style="list-style-type: none"> 1. CPR not inserted (mattress only). 2. Tubes not correctly fitted. 3. Leakage. 	<p>Check CPR (See Mattress Service Manual SER0005).</p> <p>Check.</p> <p>Check CPR (See Mattress Service Manual SER0005).</p>
Mains/Power Fail indicators (audible and visual) are active. <i>Applicable to:</i> <i>ALR 01-10</i> <i>ALX 01-10</i> <i>ALS 01-10</i>	<ol style="list-style-type: none"> 1. Mains/power failure has occurred. 2. The mains/power lead has been removed from the wall socket. 	<p>Check.</p> <p>Check.</p>

Table 29 - Troubleshooting (continued)

Problem	Possible Cause	Action
<p>Mains/Power Fail indicator remains illuminated but there is no audible alarm. <i>Applicable to:</i> ALR 01-10 ALX 01-10 ALS 01-10</p>	<p>There has been a mains/power failure but power has been restored.</p>	<p>Check if electrical plug is correctly fitted and if pump is running correctly.</p>
<p>Pump is very noisy and/or is causing excessive vibration. <i>Applicable to all pumps.</i></p>	<p>System is damaged or dirty.</p>	<ol style="list-style-type: none"> 1. Check compressor mounts for wear (Refer to Ch 3, Pg 13). 2. Check compressor is not loose on its mounting plate (Refer to Ch 3, Pg 17). 3. Check the compressor bellows are not split (Refer to Ch 3, Pg 21).
<p>Pump not operating <i>Applicable to all pumps.</i></p>	<ol style="list-style-type: none"> 1. Pump run switch not on. 2. Plug not inserted correctly. 3. Fuse blown. 4. Loss of output pressure. 	<p>Switch on.</p> <p>Check.</p> <p>Replace the fuse (Refer to Ch 3, Pg 43).</p> <p>Refer to Section 2 and 3 below.</p>
<p>All indicators/lights remain illuminated on initial switch-on. <i>Applicable to:</i> ALR 01-10 ALX 01-10 ALS 01-10</p>	<p>Internal fault</p>	<p>Test the pump (Refer to Ch 5).</p> <p>Check PCB.</p>

2 Low Pressure fault indicated (checks without dismantling the pump)

Check the following before dismantling the pump unit.

Perform the pressure, flow and low pressure alarm tests as specified in Chap. 5 (Testing). If the results are satisfactory, the mattress is at fault.

Note : All testing must be done when pumps are warm, ie. they have been running with closed ports for at least 1 hour.

Check:

- 2.1 All tubing connections on pump and mattress are securely fastened and snap locked into place.
- 2.2 Check that the rapid deflate stopper or CPR is fitted correctly (Refer to Mattress Service Manual, SER0005).

- 2.3 If the alarm still indicates, visually inspect tubing and mattress cells for punctures or tears and check they are fitted to the manifold correctly. Refer to the mattress service manual SER0005 for full details.

WARNING:

DANGER OF ELECTRIC SHOCK. DURING THE FOLLOWING TESTS, LIVE TERMINALS AND CONDUCTORS MAY BE EXPOSED. EXERCISE EXTREME CAUTION.

3 Loss of Output Pressure (checks by dismantling the pump)

If the low pressure alarm operates when both pump outlets are blocked or the pump does not pass the flow test in Chapter 5 (Testing), the pump unit internal compressor should be tested as follows:

- 3.1 Remove the rear case (Refer to Chap 3, Page 5).
- 3.2 Disconnect the white pneumatic tube from the compressor F-Tube connector.
- 3.3 Connect the pressure gauge to the compressor F-Tube connector and switch the pump unit on. The pressure reading should be at least 100 mmHg.
- 3.4 If the pressure does not reach 100 mmHg, the compressor is at fault. Either replace the compressor or remove the compressor lid, remove the silencer bag from the valve bodies and connect the pressure gauge to each valve body in turn. The pressure should be approximately 100 mmHg in each case. (Refer to Chap 3, Section 22).
- 3.5 If the required pressure cannot be reached then the bellows/armature assemblies and valve bodies must be replaced (Refer to Chap 3, Section 23). If the required pressure is obtained then the silencer bag must be replaced. (Refer to Chap 3, Section 22).

Note : The flow/pressure performance of a compressor may be altered by heating the new bellows and adjusting the 'E' stack gap.

- 3.6 If the compressor is operating correctly but the correct pressure cannot be obtained at the pump outlet then the rotor/stator, pressure control module and snap-lock connectors must be checked. Reassemble the compressor and attach pressure rig to pump outlet again.
- 3.7 Remove the gearbox and rotor/stator, clean all dust off rotor/stator and reassemble with new gasket. If rotor/stator is chipped or damaged, replace components (Refer to Chap 3, Section 37). If this does not correct the problem, check the pressure control.
- 3.8 Push on the pressure control flap (Fig 19, Item 20) to press the seal (Fig 19, Item 70) against the valve seat. Check the pressure control bag inflates fully and pushes on the flap, if not, the bag could be split - check and replace as necessary.
- 3.9 If the snap-lock connectors or tubing show signs of damage, replace. If there is still a problem, re-check in the following order:
- compressor
 - rotor/stator assembly
 - pressure control assembly
 - connections

If pressure/flow still cannot be achieved, return pump to Service department.

4 Low Pressure Alarm Fault

If the low pressure alarm does not function correctly after recalibration as described in Chap. 5 (Testing), check:

- 4.1 The electrical connections and leads between the low pressure micro-switch and the printed circuit board.
- 4.2 Check that switch is operating and n/o terminals (1-3) are in use.
- 4.3 Check free movement of lower flap.
- 4.4 Check low pressure switching point with an external pressure meter.
- 4.5 Check the pressure control module for leaks.
- 4.6 Check the location and orientation of low pressure spring and disc by removing upper and lower flaps.

5 Air Not Alternating (continuous pressure fault)

Should the cells of the mattress not inflate and deflate during a 10-minute cycle, then the timer motor may be defective (not rotating).

- 5.1 Check the timer motor electrical connections for security and integrity. If all are sound and the timer motor still does not rotate, then the timer motor must be replaced.

Notes : The timer motor is a sealed unit and cannot be repaired.

When replacing the timer motor it is advisable to replace the stator gasket at the same time. Refer to Chap. 3 (Pump Repair).

6 Loss of Electrical Power

Power loss can be due to any of the following:

- 6.1 No electricity supply at wall socket.
- 6.2 Faulty wall socket.
- 6.3 Damaged plug or mains/power cable.
- 6.4 Defective fuse link in pump or plug.
- 6.5 Damaged internal wiring.
- 6.6 Loose connections at the terminal block, micro-switch or PCB.
- 6.7 Faulty PCB component.

7 Circuit Diagrams

The circuit diagram for the electronic models is given in Fig 24. The circuit diagram for mechanical models is given in Fig 25. Check for the above faults against the relevant circuit and repair as appropriate.

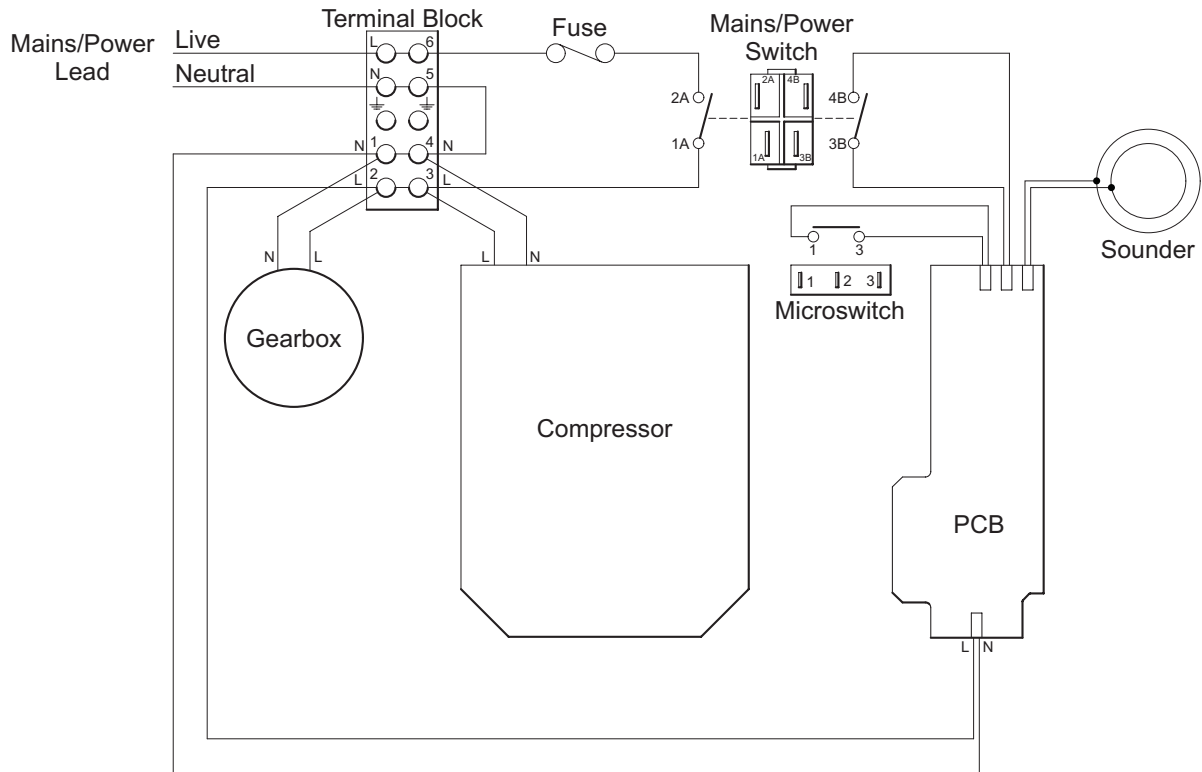

Figure 24 - Circuit diagram for Alpha Relief, Aura and AlphaXcell (Electronic) Mini Pumps

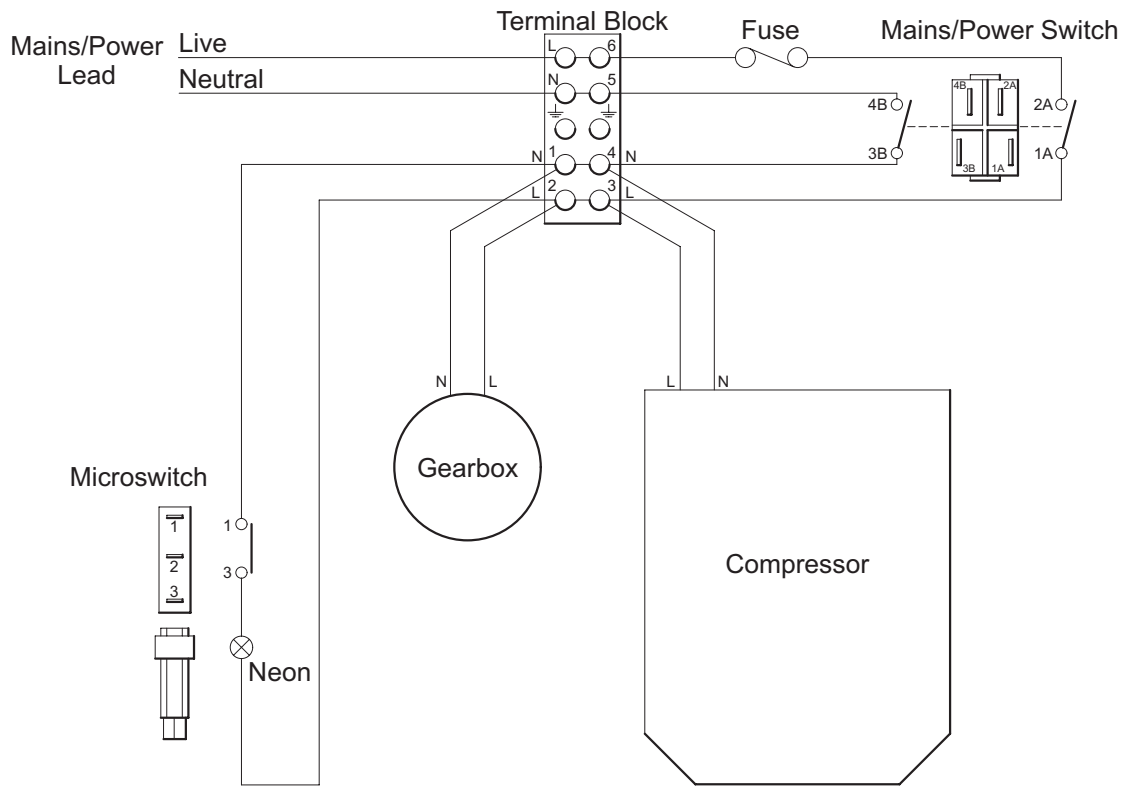

Figure 25 - Circuit diagram for AlphaXcell, AlphaBed, AlphaCare and Alpha TranCell (Mechanical) Mini Pumps

CHAPTER 5

TESTING

1 Pump Flow, Pressure and Function Test

This procedure must be carried out after a service or major repair of a pump. To test/calibrate the pump unit correctly, the following equipment or equivalent is required:

Table 30 - Pump Flow, Pressure and Function Test Equipment

Equipment	Part Number
Typical Test Kit (including):-	PRE 060
Digital Manometer (pressure gauge) 0-199 mmHg, resolution 0.1, accuracy $\pm 0.2\%$ of range.	
Flowmeter 0-10 litre/minute, resolution 0.2, accuracy $\pm 2\%$ of measured value.	
Battery, 9V Lantern	
Male Connector	BP431
Female Connector	BP432

Note : All test equipment must be calibrated to national or international standards.

Flow and Pressure Checks

- 1.1 Connect the flowmeter, via a valve, to whichever outlet is working. Connect the pressure gauge to measure the pressure at the outlet.
- 1.2 Open the valve fully. The free flow rate should not be less than specified in Table 31.

Table 31 - Minimum Flow Rates

Pump	Airflow at 20 mmHg (ltr/min)	Airflow at 50 mmHg (ltr/min)
AlphaBed	6	3
AlphaCare	6	3
Alpha Trancell	6	3
Alpha Relief	6	3
Aura	3.25	2.25
AlphaXcell	6	3

- 1.3 Close the valve and operate the pressure control knob on the pump from minimum to maximum setting. The pressure indicated on the gauge (in mmHg) should be as specified in Table 31.

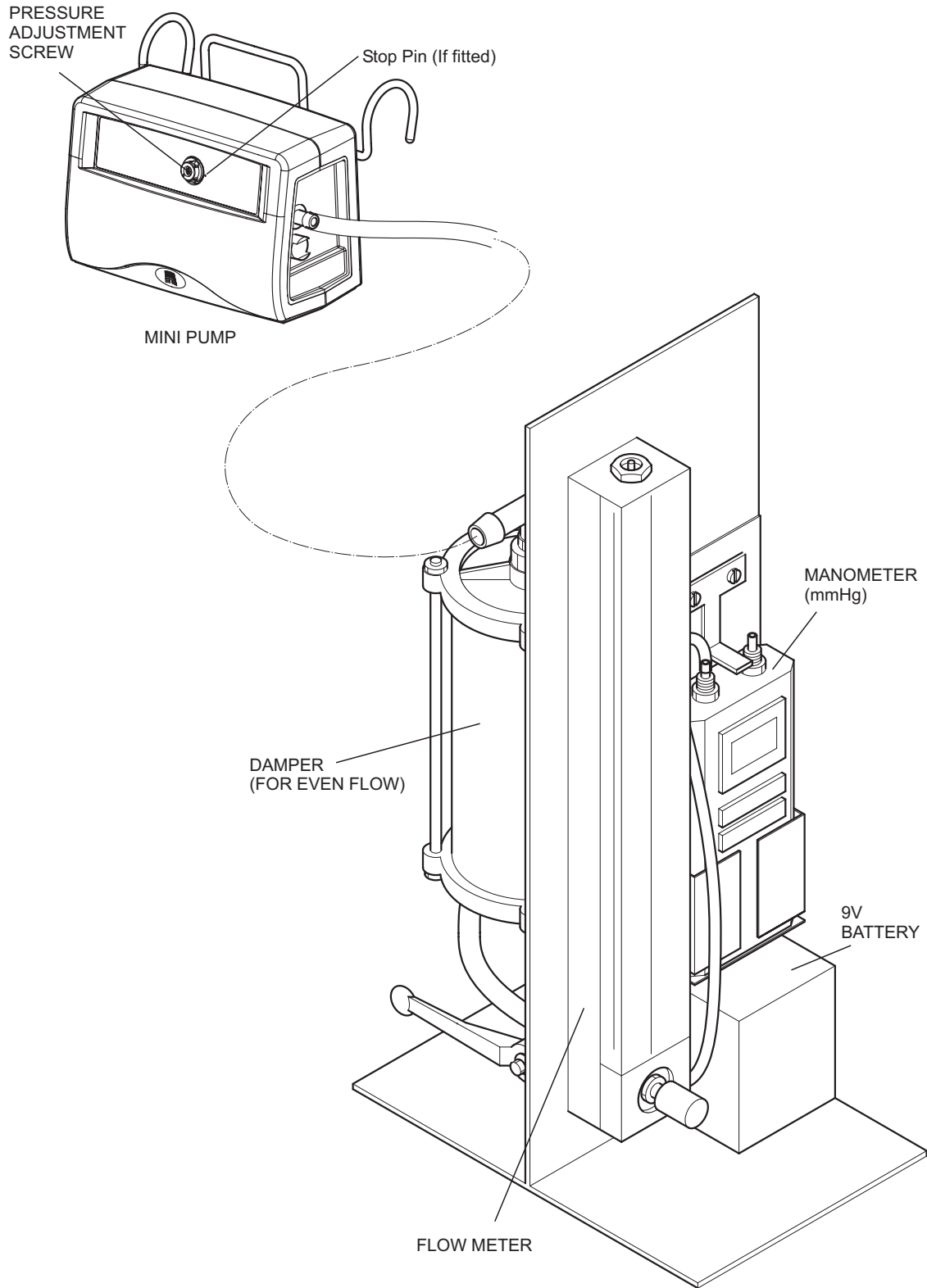

Figure 26 - Typical Test Rig setup for Mini Pumps

Table 32 - Pressure Range

Pump	Min. (mmHg)	Max. (mmHg)
AlphaBed	30 ± 5	90 ± 10
AlphaCare	30 ± 5	90 ± 10
Alpha Trancell		
ALT01-09	30 ± 5	73 ± 8
ALT10	30 ± 5	90 ± 10
Alpha Relief	22 ± 2	82 ± 10
Aura	85 ± 2	< 110
AlphaXcell	22 ± 2	65 ± 8

If the pressure readings are incorrect then calibrate the pressure control as described below.

Calibration

- 1.4 If the pressure readings are incorrect then calibrate the pressure control as follows:
- 1.4.1 Turn the pressure control knob to the minimum setting.
 - 1.4.2 Using a small, flat bladed screwdriver, carefully remove the pressure control knob. Be careful not to move the arbour.
 - 1.4.3 Rotate the screw in the centre of the pressure control arbour (counter-clockwise to increase) until the indicated pressure is as specified in Table 33.

Note : Ensure that the pressure control arbour does not move.

Table 33 - Indicated Pressure

Pump	Indicated Pressure	
AlphaBed	30 mmHg	Set at dead centre value
AlphaCare	30 mmHg	
Alpha Trancell	30 mmHg	
Alpha Relief	22 mmHg	
Aura	55 mmHg	
AlphaXcell	22 mmHg	

- 1.4.4 Carefully replace the pressure control knob, ensuring that the control knob rotation is limited between the minimum setting and the stop pin (if fitted).
- 1.4.5 Check the indicated pressure at minimum and maximum settings (Refer to Table 32) and readjust if necessary.
- 1.4.6 Variation between the ports is to be no greater than 4 mmHg.
- 1.4.7 Attach the flow meter tube to whichever outlet is the duty port and check the free flow again. The flow readings should be as specified in Table 31. Variation between the ports is to be no greater than 1 litre/minute.

Low Pressure Indicator Test (Mechanical Units Only)

- 1.5 With the test equipment set up as in Section 1.1, set the pressure control knob in the mid position and use the flowmeter valve to adjust the pressure slowly up and down.
- 1.6 Observe the **LOW PRESSURE** warning light to indicate the operation of the Micro switch.
- 1.7 The micro switch should activate at or before the pressure reaches 5 mmHg descending and deactivate at or before the pressure reaches 20 mmHg ascending.

Low Pressure Indicator Test (Electronic units only)**WARNING**

DANGER OF ELECTRIC SHOCK. DURING THE FOLLOWING TESTS, LIVE TERMINALS AND CONDUCTORS MAY BE EXPOSED. EXERCISE EXTREME CAUTION.

Note: Pump units fitted with an alarm monitoring PCB should have the low pressure alarm settings tested within 60 seconds of switching the pump on.

- 1.8 Remove the rear case assembly (Refer to Chap 3, Section 6).
 - 1.8.1 Fit snap-lock connectors to both outlet ports. Connect the pressure gauge and a bleed valve to the duty port.
 - 1.8.2 Connect a buzzer or LED to the microswitch terminals to indicate microswitch operation (see Chap 4, Fig 24 for microswitch terminal connections).
 - 1.8.3 Ensure that the bleed valve is fully closed, Ensure that the low pressure adjustment screw (on the upper flap) is fully disengaged. Turn the arbour clockwise and counter-clockwise over the full range three or four times. Leave it in the fully counter-clockwise position.
 - 1.8.4 Turn the pressure control knob until the indicated pressure is 50 mmHg (maximum setting for Aura models only).
 - 1.8.5 Open the bleed valve to induce a leak, until the pressure is 10 mmHg (60 mmHg for Aura models only).
 - 1.8.6 The microswitch should activate before the pressure reaches X mmHg descending and deactivate before the pressure reaches Y mmHg ascending, as specified in Table 34.
 - 1.8.7 Set the low pressure adjustment screw so that the microswitch activates at this set level. Do this very slowly. Adjust the pressure up and down by means of the bleed valve and verify that the microswitch goes on and off accordingly.
 - 1.8.8 Replace the rear cover (Refer to Chap 3, Section 7).

Table 34 - Descending and Ascending Pressures

Pump	Pressure X	Pressure Y
AlphaBed	5 mmHg	17 mmHg
AlphaCare	5 mmHg	17 mmHg
Alpha Trancell	5 mmHg	17 mmHg
Alpha Relief	5 mmHg	17 mmHg
Aura	50 mmHg	82 mmHg
AlphaXcell	5 mmHg	17 mmHg

2 Electrical Testing

To test and calibrate the pump unit correctly, the following equipment is required:

Table 35 - Electrical Test Equipment

Equipment
Insulation resistance tester (Megger) 500 Vdc
Portable appliance tester
Multimeter/Continuity tester
Dielectric strength tester (Flash tester) 3.0 kVac with current limit

Electrical Safety Checks – Class II

There are several electrical safety checks that must be carried out after breakdown repairs, rental re-checks and servicing. Where alternatives are given, the test will depend upon the available equipment. The tests are as follows:

- Insulation Resistance Test (Megger Test) or
- Dielectric Strength (Flash Test)

Insulation Resistance Test

This test checks the integrity of the appliance's insulation.

For all appliances, this test is applied between the connected Live and Neutral wires and the appliance's metal compressor assembly box.

Specification: 500 Vdc is applied to the insulation and the measured resistance must be greater than 2 MΩ. This test can be conducted by using a Portable Appliance Tester. Also check the continuity of the mains cable.

Dielectric Strength Test (Flash Test)

This test shows the response of the insulation to high ac-voltage stress, to the effects of the capacitive current and gives an early warning of any electrical problems developing in the appliance.

Leakage Circuit Test (USA)

Measure the risk currents in accordance with the ANSI-AAMI ESI-1993 Standard (American National Standard Safe Current Limits for Electromedical Apparatus) or as specified in UL 2601-1.

WARNINGS:

DANGER OF ELECTRIC SHOCK. DO NOT TOUCH ANY EXPOSED PARTS WHILE CONDUCTING THIS TEST. DO NOT TOUCH ANY PART OF YOUR BODY WITH THE CONTACTS OF THE PROBES.

THIS EQUIPMENT SHOULD NOT BE USED IF YOU HAVE A HEARING AID OR PACEMAKER FITTED, DUE TO THE POSSIBILITY OF ELECTROMAGNETIC DISTURBANCE.

Specification: 3.0 kVac is applied between the connected Live and Neutral wires and the appliance's metal compressor assembly box. No breakdown should occur.

Note : The voltage levels used for this test, may stress and weaken the insulation. This test, is therefore not recommended as a routine test. It should only be used after a major assembly/disassembly has been completed.

3 PCB Functional Tests (Electrical Units Only)

Tests must be carried out using a 220-240 V, 50 Hz power supply.

Test Setup and Initial Switch On

- 3.1 Install the mating parts of the snap-lock connectors on the pump outlets so that both outlets are open to atmosphere. Set the pressure control knob fully counterclockwise.
- 3.2 Connect the mains/power cable to a suitable power socket outlet and then set the run/standby switch to 'run'. All four indicator lights should illuminate and the audible alarm should sound for about 3 seconds. The green **ON** indicator, the amber **WAIT** indicator and the **LOW PRESSURE** indicator will remain on. The **POWER FAIL** indicator light should extinguish.

Power Fail Alarm Check

- 3.3 With the pump operating, disconnect the power supply at the power socket outlet then reconnect it after 4 seconds. Verify that no alarms are given and normal operation is resumed.
- 3.4 Again disconnect the power supply at the power socket outlet. Verify that, after 5 seconds, the red **POWER FAIL** indicator flashes in conjunction with the audible alarm. The **WAIT** indicator should go off when the **POWER FAIL** alarm indicator flashes. Reconnect the power supply. Verify that the **POWER FAIL** indicator is extinguished.
- 3.5 Operate the run/standby switch to 'standby' and verify that all indicators are off. After 5 seconds, operate the switch back to 'run'. Verify that all alarm indications are cleared and normal operation is resumed. Operate the run/standby switch to 'standby'.

Low Pressure Alarm Check

- 3.6 Use suitable sealing caps to close the ports. Operate the run/standby switch to 'run'. Verify that, after 1 minute, the **WAIT** indicator is extinguished.
- 3.7 Open both ports to atmosphere. Verify that, after 4 minutes and 45 seconds, the red **LOW PRESSURE** indicator flashes in conjunction with the audible alarm.
- 3.8 Operate the run/standby switch to 'standby' and back to 'run'. Verify that all alarm indications are cleared and normal operation is resumed.

4 Functional Tests (Mechanical Units Only)

Tests must be carried out using a 220-240 V, 50 Hz power supply.

Test Setup and Initial Switch On

- 4.1 Set the pressure control knob fully counter-clockwise and ensure that both outlet ports are open to atmosphere.
- 4.2 Connect the mains/power cable to a suitable power socket outlet and then set the on/off switch to 'on' (☉). Verify that the green indicator in the switch is illuminated. Verify that the red **LOW PRESSURE** indicator is illuminated. Use the fingers to close both outlet ports and verify that the **LOW PRESSURE** indicator goes off.

CHAPTER 6

TECHNICAL SPECIFICATION

Pump Models

The pump models covered in this series are:-

- Alpha Relief
- Aura
- AlphaXcell (Electronic)
- AlphaXcell (Mechanical)
- AlphaBed
- AlphaCare
- Alpha Trancell

Notes : Each model has a three letter code. For example, the Alpha Relief pump has the code ALR.

Following the three letter code is a two digit code representing customer country's power supply system. For example, the Alpha Relief pump is available to countries 01, 02, 03 and 04 (UK, Germany, USA and Europe-general respectively).

A complete breakdown of the pump model three letter codes and two digit codes is given in Chap. 1, Tables 1 and 2.

Size

All pumps are 248 x 160 x 116 mm (9.8 x 6.3 x 4.6 inches).

Weight

All pump models are 2.75 kg (6 lb).

Pressure Ranges

Model	Min (mmHg)	Max (mmHg)
Alpha Relief	22 ± 2	82 ± 10
Aura	85 ± 2	<110
AlphaXcell	22 ± 2	65 ± 8
AlphaBed	30 ± 5	90 ± 10
AlphaCare	30 ± 5	90 ± 10
Alpha Trancell ALT01-09	30 ± 5	73 ± 8
Alpha Trancell ALT10	30 ± 5	90 ± 10

Cycle Time

The cycle time for all pump models is 10 minutes.

Rated Voltages

The voltage ratings for each of the customer (two digit) codes is given in Chap. 1, Table 2.

Rated Frequency

The mains/power frequency ratings for each of the customer (two digit) codes is given in Chap. 1, Table 2.

Rated Input Power

The rated input power for all pump models is 14 VA.

Running Time

All pump models are designed for continuous consumption.

Test Standards

All pumps are tested to:

Europe	En 60601-1
USA	UL 2601-1 (Classified by Underwriters Laboratories Inc.®) with respect to electric shock, fire and mechanical hazards only in accordance with UL 2601-1.
Canada	CSA C22.2 No. 601-1 (Classified by Underwriters Laboratories Inc.®) with respect to electric shock, fire and mechanical and other hazards only in accordance with CAN/CSA C22.2 No. 601.1.

For the AlphaBed, AlphaCare and Alpha Trancell pumps, standards BS 5724 (part 1) 1989 and VDE 0750: Teil also apply.

Protection Class

The protection class for all pump models is Class II, type BF. The pumps are not protected against the ingress of water.

Indicator Lights

The Alpha Relief, Aura and AlphaXcell (electronic) have four indicator lights:

- Power On
- Wait (except Aura)
- Low Pressure
- Power Fail

The AlphaXcell (mechanical), AlphaBed, AlphaCare and Alpha Trancell have one indicator light:

- Low Pressure

Environmental Conditions

Operating conditions for all models:

Temperature range:	+10° C to +40° C
Relative humidity:	30% to 75%
Atmospheric pressure:	700 hPa to 1060 hPa

Storage conditions for all pump models:

Temperature range:	-40° C to +70° C
Relative humidity:	10% to 100% (non-condensing)
Atmospheric pressure:	500 hPa to 1060 hPa

Disposal: All units must be disposed of in accordance with local environmental regulations.

CHAPTER 7

PARTS LIST

Part Number	Description	Fig-Item	Qty
Front and Rear Case			
500316	Front Case	2 - 40	1
500318	Pin (if fitted)	2 - 30	1
500484	Control Knob (MK2)	2 - 10	1
500304	Knob Arbour	2 - 20	1
500317	Rear Case	3 - 30	1
500340	Felt Filter	3 - 10	1
500327	Filter Plate	3 - 20	1
FAS223	Pan Head Screw PT 3 Dia x 10 Pozi	3 - 40	1
FAS225	Pan Head Screw PT 3 Dia. x 16 Pozi	3 - 50	4
500495	Bed Hook (New Style)	4 - 10	1
500496	Hook Plate (Left Hand)	4 - 20	1
500497	Hook Plate (Right Hand)	4 - 30	1
FAS223	Pan Head screw PT 3 Dia. x 10	4 - 40	8
500381	Rubber foot	4 - 50	8
Label Sets (See Chap 3, Page 47, Table 28)			
Compressor Assembly			
502003	Compressor Assy 230V 50Hz 11K/T	6 - 10 10 - 10	1
502002	Compressor Assy 110V 60Hz 5K/T (USA)	6 - 10 10 - 10	1
502007	Compressor Assy 100V 50/60Hz 4.5K/T (Japan)	6 - 10 10 - 10	1
502054	• Bellows Armature Assembly Left-Hand 230V 50Hz	11 - 10	1
BP215	Bellows Armature Assembly Left-Hand 110V 60Hz		1
502053	• Bellows Armature Assembly Right-Hand 230V 50Hz	11 - 20	1
BP214	Bellows Armature Assembly Right-Hand 110V 60Hz		1
BP043	• Armature Pivot	11 - 30	2
BP554	• Valve Body Assy, Blue	11 - 40 12 - 10	2
BP351	• • Valve Body	12 - 20	1

Part Number	Description	Fig-Item	Qty
FAS027	• • Screw, Hex Head 4BA x 3/4	12 - 30	1
FAS013	• • 4BA Full Nut	12 - 40	1
BP039	• • Valve Body Washer	12 - 50	2
BP037	• • Valve Flap	12 - 60	2
BP038	• • Valve Flap Securing Pad	12 - 70	2
BP028	• 'E' Stack	13 - 10	1
FAS048	• Pan Head Screw M3 x 25 mm Pozi	13 - 20	2
FAS002	• Washer - 6BA Anti-Vib.	13 - 30	2
502050	• Coil Assembly 230V 50Hz (black/white leads)	13 - 40	1
502062	Coil Assembly 110V 60Hz (grey leads)		1
BP275	Coil Assembly 100V 50/60Hz (blue leads)		1
165303	• Grommet	13 - 50	1
502304	• Compressor Case	13 - 60	1
502301	• Compressor Lid	10 - 20	1
BP032	• Compressor Gasket	10 - 40	1
502055	• Silencer Bag	10 - 50	1
500320	'F' Tube Connector	6 - 20 10 - 60	1
500410	Filter Retaining Clip	6 - 30	1
500417	Inlet Filter	6 - 40	1
500124	Compressor Mounting Bracket (New style)	7 - 10	1
500416	AV Mount (New style)	7 - 20	4
198375	AV Mount (Old style)	8 - 20	4
165310	Upper Bump Stop	9 - 10	1
165310	Lower Bump Stop	9 - 20	1
FAS160	Washer M4 Plain	9 - 40	2
FAS051	Screw Pan Head Pozi M4 x 6 mm	9 - 50	2
FAS095	Screw Pan Head Pozi M4 x 10 mm	9 - 60	3
FAS054	Screw Countersunk Pozi M4 x 12 mm	10 - 30	4
Pressure Control Module			
500347	Terminal Block 5 way	14 - 10 18 - 30	1

Part Number	Description	Fig-Item	Qty
BP196	Cable Tie	14 - 20	2
500362	Tube Sil ID 3/16" 135 mm ± 5 mm LG	14 - 30	1
FAS145	Screw 3 Dia. x 8 mm Pozi Pan Head PT	14 - 40	1
FAS223	Screw 3 Dia. x 10 mm Pozi Pan Head PT	14 - 50	3
500315	Panel Side Colder	14 - 60	1
500328	Panel Side Push On	14 - 70	1
151309	Fixing Cap	14 - 80	1
500338	Micro switch Sub Min 230 V/0.1A	18 - 10	1
FAS224	Screw 2.2 Dia. x 14 mm Pozi Pan Head PT	18 - 20	2
500347	Terminal Block 5 Way	18 - 30	1
FAS225	Screw 3 Dia. x 16 mm Pozi Pan Head PT	18 - 40	2
500304	Knob Control Arbour	19 - 10 20 - 60	1
500312	Upper Pressure Control Flap	19 - 20	1
500318	Pivot Pin, Pressure Control	19 - 30	1
550303	Lower Pressure Control Flap	19 - 40	1
500341	Spring 0,024" Diameter	19 - 50	1
151339	Pressure Control Disc	19 - 60	1
PRE022	Rubber Valve Disc	19 - 70	1
500103	Bag Pressure with Restrictor Assembly	19 - 80	1
500355	Screw M3 x16 mm Socket Cap Hd Black	19 - 90	1
403306	Restrictor (Aura Pumps Only)	19 - 100	1
FAS225	Control Adjustment Screw, 3 Dia x 16 mm Pozi Pan Head PT	20 - 10	1
500305	Knob Control Cam	20 - 20	1
500411	Cup Arbour Drive Spring	20 - 30	1
500339	Spring Comp 1.07 Diameter	20 - 40	1
500349	Pressure Assembly Module	20 - 50	1
FAS223	Screw 3 Dia x 10 mm Pozi Pan Head	21 - 10	2
500097	Gearbox 240V and Ferrule Assembly	21 - 20	1
500098	Gearbox 120V and Ferrule Assembly		1
500099	Gearbox 100V and Ferrule Assembly		1
151409	Motor Gearbox 100V, 50 Hz, 1/10 RPM		1

Part Number	Description	Fig-Item	Qty
500308	Rotor Module	21 - 30	1
500307	Stator Module	21 - 40	1
500332	Felt Rotor Silencer	21 - 50	1
500319	Stator Gasket	21 - 60	1
500418	Stator Gasket (Restricted)		1
500356	Rotor Drive Cup	21- 70	1
500322	Pin Rotor Drive	21- 80	1
500354	Washer Starlock O/D 21 mm	21- 90	1
500358	Spring Comp 1.6 Diameter FL 22.36	21- 100	1
TIM017	Oil Seal Cap	21- 110	1
PCB (Electronic versions only)			
500346	PCB Alarm Monitoring 230 V	15 - 20	1
500345	PCB Alarm Monitoring 100/120 V		1
151457	• Battery	16 - 10	1
FAS083	Screw No. 6 x 5/16" Pozi Pan Head PT	15 - 10	1
Neon Indicator (Mechanical versions only)			
500324	Plate Neon Mounting	17 - 20	1
500373	Neon Assembly Red 230 V	17 - 30	1
500371	Neon Assembly Red 110 V		
FAS083	Screw No. 6 x 5/16" Pozi Pan Head PT	17 - 10	1
Mains/Power Switch and Supply			
500351	Switch Mains/Power Rocker 230 V Black (All electronic pumps)	22 - 10	1
500343	Switch Mains/Power Rocker 230 V Green (Illuminated)		1
500359	Switch Mains/Power Rocker 110 V Green (Illuminated)		1
198315	Grommet	22 - 20	1
BP532	Cordset Standard Moulded UK (Cable)	22 - 30	1
CAS041	Mains/Power Cable - European "Shuko" Socket		1
BP087	Mains/Power Cable - USA 2 pin		1
CAS020	Mains/Power Cable - Japan 2 pin		1

Part Number	Description	Fig-Item	Qty
BP171	Mains/Power Cable - Australia		1
500344	Fuse Holder	22 - 40	1
CAS011	Fuselink 20 x 5 mm 500 mA QB	22 - 50	1
Snap-lock Connectors			
500350	Connector Panel, Female 1/4" Flow	23 - 10	1
504316	Connector Panel, Male 1/4" Flow	23 - 20	1
500361	Tube Sil Blue ID 6 OD 10 24 LG ± 1	23 - 30	1
500360	Tube Sil Blue ID 6 OD 10 15 LG ± 1	23 - 40	1
Service Kit			
500135	Service Kit (240v only)		
BP043	• Armature Pivot		2
502055	• Silencer Bag		1
502053	• Bellows Armature Assembly Right-Hand 230v 50Hz		1
502054	• Bellows Armature Assembly Left-Hand 230v 50Hz		1
500340	• Felt Filter (Case)		1
500417	• Inlet Filter (Compressor)		1

CHAPTER 8

SERVICE CONTACT DETAILS

Africa

Huntleigh Africa (Pty) Limited
126 B Sarel Baard Crescent
Rooihuiskraal, Pretoria, South Africa
T +27 1266 10368
F +27 1266 10380

Australia

Huntleigh Healthcare Pty Limited
63 Buckingham Drive, Wangara,
Western Australia 6065
T +61 8 9 309 3083
F +61 8 9 309 4582

Belgium

Huntleigh Healthcare NV SA
Stapelplein 70, 9000 Gent, Belgium
T +32 9 265 8770
F +32 9 265 8771

Denmark

Huntleigh Healthcare, Denmark
Hejreskovvej 18A
DK-3490 Kvistgard, Denmark
T +45 4 913 8486
F +45 4 913 8487

France

HNE Médical SA
Parc d'affaires Silic 6, 1 Rue des Vergers
69760 Limonest, France
T +33 (0)4 78 66 62 66
F +33 (0)4 78 66 62 67

Germany

HNE Huntleigh Nesbit Evans
Healthcare GmbH
Im Hülsenfeld 19, 40721 Hilden, Germany
T +49 (0)2103 97 11 0
F +49 (0)2103 97 11 80

Holland

Huntleigh Healthcare BV
Flevolaan 8, 1382 JZ Weesp, Holland
T +31 294 415001
F +31 294 430475

India

Indian Liaison Office
61 Goldmist, Gulmohar Road
Juha Scheme, Mumbai 400 049, India

Middle East

Huntleigh Technology PLC
307 Sh. Zayed Road
Dubai, United Arab Emirates

New Zealand

Huntleigh Healthcare Ltd
Unit 6/38 Eaglehurst Road,
Ellerslie, Auckland, NZ
T +64 9 525 2488
F +64 9 525 2433

Singapore

Huntleigh Healthcare, Singapore
6 Temasek Boulevard, Fourth Floor
Sunlee Tower Four, Singapore
T +61 8 9 309 3083
F +60 8 9 309 4582

Sweden

Huntleigh Liljenberg AB
Limhammsgårdens alle 15
21610 Limhamn, Malmo, Sweden
T +46 40 49 57 80
F +46 40 49 43 75

UK

Huntleigh Healthcare Limited
310-312 Dallow Road,
Luton,
Bedfordshire, LU1 1TD
T +44 (0)1582 413104
F +44 (0)1582 459100

United States of America

Huntleigh Healthcare Inc
40 Christopher Way
Eatontown, NJ 07724, USA
T +1 732 578 9898
F +1 732 578 9889

Huntleigh Latin America Inc
2602 North West 97th Avenue,
Miami, Florida, 33172, USA
T +1 305 463 0526
F +1 305 463 0216

