

# ElectraGlide User Manual

2021 VERSION



## IMPORTANT

For your safety and comfort read carefully and understand all of the features prior to using your new Glide Rehabilitation Products chair.



# Table of Contents

Section 1	Introduction	4
Section 2	Standard Features	5
Section 3	Warnings	6
Section 4	Folding And Unfolding Your Chair	9
Section 5	Transporting Your Power Chair	11
Section 6	Operating Your Power Chair	12
Section 7	Battery Charging And Maintenance	13
Section 8	Routine Maintenance	14
Section 9	Trouble Shooting	15
Section 10	Dynamic Shark Controller	16
Section 11	Precautions For Controller Use	4
Section 12	Transferring To And From Your Power Chair	5
Section 13	Environment Precautions	6
Section 14	Radio Frequency Interference	9
Section 15	Battery Wiring Diagram	11
Section 16	Spare Parts	12
Section 17	Warranty	13

## SECTION 1 | INTRODUCTION

# Thank you for choosing the RocketGlide Wheelchair

An Australian designed and manufactured product, which complies with AS 3695 and has a manufacturers recommended maximum user weight of 150Kg.

With proper care and operation your wheelchair will provide years of trouble free mobility.

Please take the time to familiarise yourself with the functions and features of your power chair by reading this Owners Manual. If you have any queries about the functions of the chair you can call Glide Rehabilitation Products or your nearest Glide dealer.



**Warning.** Means you must read.

If you have a Vertical Lift model, it is essential you read and fully understand Section 11 before use.

## SECTION 2 | STANDARD FEATURES

# The RocketGlide Wheelchair



**Identifying Parts on your Wheelchair (Fig. 1)**

- |   |                             |
|---|-----------------------------|
| 1. Standard Non - Adjustable Height Armrests              | 7. Swing Away Footrests     |
| 2. Battery Pack (with built in lifting strap)             | 8. Dynamic Shark Controller |
| 3. Drive Clutch   | 9. High Torque Motors       |
| 4. Attendant Brakes                                       | 10. Folding Frame           |
| 5. Pneumatic Front Castor Wheels<br>200mm x 50mm (8"x1¼") | 11. Sail Cloth Upholstery   |
| 6. Pneumatic Rear Wheels<br>203mm x 62mm (12 ½" x 2 ¼")   | 12. Velcro Calf Strap       |

**Maximum Safe Slope** = 12 Degrees moving  
**Maximum Obstacle Climbing** = 48mm forward  
36mm backwards with anti-tip wheels fitted

## SECTION 3 | WARNINGS

### To The User

1. Before using this chair, obtain advice and training from your health professional.
2. Each chair is custom designed to suit individual needs. Take time to become familiar with each feature before you begin driving.
3. Depending on your level of function and ability, you will need to develop your own methods for its safe use.
4. Understanding the environment where the chair will be used will help identify potential hazards and how to avoid them.
5. Read this manual before operating chair.
6. **Never take chair onto stairs or escalators.**

### To The Carer

1. You must read this manual and follow all the instructions in each section as they also apply to you.
2. You must develop an understanding of the occupants ability to develop safe methods best suited to your ability
3. To manually push the chair you must make sure that you have control over the chair before releasing the motor drive clutch.
4. Only use the push handles to move chair. They are specifically designed for this purpose
5. When helping the occupant overcome an obstacle you must:
  - Learn safe methods from your health professional
  - Explain clearly to the occupant what you are about to do and what they are required to do
  - Always go straight up or down when traversing curbs or steps. Never attempt angled approaches or descents as it effects stability of the chair.
  - Never let the chair drop back to the ground when going over edges of steps and obstacles. Doing so may cause damage to chair or injury to the occupant
6. **Never take chair on to stairs or escalators.**



## Environment Conditions

The Glide Rehabilitation Products Power Chair has been designed and tested with user safety, as it's prime consideration. This however, does not negate the effect or take into account, circumstances, which put the wheelchair outside the specified operating conditions for which it was designed and tested. It is important that the user takes due care and understands the limitations within the environment that the chair will be operated.

As a guide only, the following is a brief list of scenarios that could affect the stability of the chair and need to be considered when driving chair:

- Traction could be lost on inclined, wet, grassy surfaces.  
Take extra care and drive slowly on these surfaces.
- Never drive your chair on a wet, oily or icy covered ramp or slope
- Stop if one or both drive wheels lose traction
- Never traverse railway lines without someone in attendance
- Chair should not be driven in heavy rain
- Never use your chair in a shower, swimming pool, sauna, ocean or lake
- If your environment has many steep obstacles, always have someone in attendance to assist you.
- Never drive your chair in sand or over rough surfaces. Doing so may cause damage to wheels, bearings, gearboxes and motors.
- Do not descend if already on slope.
- Always approach curbs square. Never on an angle. Castor will spin and lock if approach angle is not 90 degree.
- Whilst driving, the ON/OFF switch on the controller should only be switched OFF in an emergency. The wheelchair will come to a fast controlled stop rather than sudden stop.



## Ramps & Inclines

When your chair is on a ramp or incline the centre of balance of your chair will change. Your chair is less stable when on ramps or inclines and should not be used unless you feel it is safe to do so. If in doubt have someone with you. Do not use the chair on a slope of greater than 10 degrees. **When going up an incline or ramp you must:**

- Approach the ramp or incline straight on.  
Do not approach on an angle (cut the corner)
- Make sure that you are in the centre of the ramp  
and that the ramp is wide enough for your wheelchair

- Not use ramp if you feel that a wheel may drop off the side
- Not veer or turn while on ramp. This may cause chair to tip and a fall may result.
- Drive chair at a slow, steady speed. Keep chair moving.

**When going down a ramp or descent you must:**

- Always use the centre of the ramp or descent
- Not veer or turn while on ramp or descent.
- Drive chair at a slow steady speed .Do not allow chair to accelerate over normal speed. Centre the joystick to allow it to slow down or stop.
- Never use attendant brakes to slow or stop the chair.  
This may cause the chair to veer or change direction erratically.
- Never attempt climbing ramps with high degree of seat tilt.
- Approach the ramp or incline straight on.  
Do not approach on an angle (cut the corner)
- Make sure that you are in the centre of the ramp and that the ramp is wide enough for your wheelchair
- Do not use ramp if you feel that a wheel may drop off the side.
- Do not veer or turn while on ramp. This may cause chair to tip and a fall may result.
- Drive wheelchair at a slow, steady speed. Keep chair moving.
- Return tilt and recline to normal driving position when back on level ground.



## RFI

All electronic devices generally radiate some type of Radio Frequency Interference (RFI). The manufacturer of the wheelchair control systems, have made every effort to minimise the effect of RFI so as not to cause problems under normal circumstances.

Even with the efforts by the manufacturer to minimise effects of RFI, the chair control system may still be affected in areas with strong RFI signals.

If for any reason, your chair behaves in an abnormal manner, shut the wheelchair off immediately.

Before continuing, the user must be confident that the system is performing normally. If not, turn chair off and contact your carer or Glide Rehabilitation Products Agent for repair.



## Controllers

Your wheelchair has been supplied with a fully programmable controller, which has the ability to fine-tune many driving parameters using special equipment and a PC.

At time of specification your chair would have been programmed to best suit your individual function and ability.

Drive the chair in the mode and speed level that best suits the environment so as not to cause injury to yourself or others.

Have an authorised Glide Rehabilitation Products agents make adjustments to the controller if the chair is not performing to your satisfaction. There are no controller adjustments that can be made by the user or carer apart from speed level selection.

## Safety/Performance Check

Make sure the chair operates as it is designed to do. If there is a change in the performance of the chair or in your functional ability, contact your nearest Glide Rehabilitation Products agent to reprogram the control settings to match your needs. It is advisable to have these settings checked annually. Check for any uncharacteristic noises, vibration or any difficulty in its use.

If a problem is found, notify your carer and Glide Rehabilitation Products agent for repair or advice on how to repair. Do not drive it if your safety is at risk. Make sure that the batteries are fully charged before operating. The Green float light on the charger will indicate that the batteries are fully charged. Make sure all tyres are inflated to recommended pressures and in good condition. Make sure all accessories are secure and in correct position.

Check that the electronic brakes work correctly. (When chair is turned on with motors engaged and hand off the joystick, you should not be able to push the chair or rotate the drive wheels).

## Modifications

Never make any modifications or use non-approved Glide Rehabilitation Products parts on your power chair. Doing so may cause a safety hazard and could void Warranty.

Unauthorised changes constitute remanufacturing of the power chair. This voids any warranty. The person or group who make the changes will have full liability of the power chair.



## SECTION 4 | FOLDING & UNFOLDING POWER CHAIR

# Assemble or Disassemble Parts

### Removal of battery Box

1. Unclip battery lead connector
2. Pull out both locking pins A (see diagram) and twist so they hold in the out position
3. Lift battery box out using lifting strap (velcro lid retaining strap)

### Folding of Power Chair

1. Lift up Left and Right footplates
2. Remove spreader bar (if fitted)
3. Lift seat upholstery directly upwards to fold chair

### Assembly of Power Chair

1. Unfold chair taking care not to put your fingers under seat upholstery bar – push down and out on seat upholstery bars.
2. Lift battery box into chair using lifting strap ( Velcro lid retaining strap)
3. Plug in battery lead connectors. Twist and push in both locking pins A (see diagram)



**Battery box +16kg.**



# How to Transport Wheelchair

Transporting your Power Chair in motor vehicles can be easily achieved by the following method.

## **Sedan or Station Wagon**

The Series 4 is easily transported in Sedans or Station wagons by the following method:

1. Removing battery pack from chair and folding together allowing you to lift into boot or back of station wagon

## **Transporting in a Special Wheelchair Taxi, Bus or Private Vehicle While the User is in the Chair.**

To date there is no recognized Australian Standard that covers wheelchairs suitable for vehicle transport while the user is in the chair. However the Series 4 is suitable for transport provided the appropriate tiedown brackets are fitted to the chair and a 4 point restraint system (Unwin) is used. Where possible, wheelchair occupants should be transferred into and use the proper vehicle seat and restraints. However, if your chair is to be transported in a vehicle, your vehicle restraint system must comply with AS2942 – 1994.



**Do not use legrests or footplates as attachment points for your tie down system.**

**Do not use armrests as attachment points for your tie down system.**

**Unoccupied wheelchairs in vehicles must be safely secured or stored securely outside the passenger compartment.**

**Posture Positioning Belts should not be used as vehicle restraint belts.**

**NOTE:** Ensure that your restraint system complies with AS2942 and you fully understand the manufacturer instructions on how your tie down system works and whether it is compatible with the Glide Power Chair.

## SECTION 6 | OPERATING YOUR POWER CHAIR

# Controller

Your new Power Chair has been supplied with the Dynamic Controls control system. You will have been given instruction on how to operate your controller at time of specification.



**Never push the On /Off button or pad on the control box until you are seated correctly in the chair and have your hand on the control box.**

**IMPORTANT:** Please familiarise yourself with the individual functions of your controller in particular the On/Off button or pad. The control systems have an On/Off button or pad that operate by pressing once for ON and pressing the same button or pad again for OFF.

1. Do not displace the joystick when pressing the On button or pad.
2. Never press the On/Off button or pad while driving your power chair.
3. To avoid damage to motor gearboxes always come to a complete “stop” before turning your power chair off,

# Armrest

Armrests are removable. With those chairs fitted with adjustable height arms they are incrementally adjustable in height. To adjust, simply depress the two button locks located on outside of bottom frame, move to desired height and ensure that button locks “spring” back into the holes nearest to your desired height.

To remove armrests from chair, simply depress button lock in front armrest mounting socket and lift armrest out. See Figure 3.

# Footrests

The footrests are swing away and detachable. They swing out by either pushing or pulling the release lever. The type of release lever fitted to your chair depends on your ability and footplate type fitted to your chair. When lever is released the footplate will simply swing out and lift off the two locating pins. When refitting footrest to chair ensure that it is located on both locating pins. Damage may result if only one pin is used.

## Height Adjustment of Footplate

Your footplate will be fitted with one of two types of adjustment styles.

1. Clamp Type – to adjust height simply undo clamp bolt, move to desired position, retighten clamp bolt.

2. Incremental Hole Type – to adjust height simply un - do and remove bolt, move footplate to nearest hole to suit desired height, replace and tighten bolt firmly.

## Drive Clutch

The drive clutch is located in the centre of each driving wheel. It is identified as a large Black Plastic Knob.

To ENGAGE, simply turn Black Plastic Knob (drive clutch) in either direction until you here a “click”. Turn chair on and SLOWLY move joystick forward until drive clutch self engages.

To DISENGAGE simply pull out and 1/8th turn the Black Plastic Knob (drive clutch). This will allow the chair to be free wheeled.



**Disengaging drive clutch and moving chair while on a slope may be dangerous. Automatic electronic brakes will not function.**

## Brakes

Your power chair has electronic brakes and they are activated in the flowing manner.

1. If chair suffers a power failure while driving
2. When joystick of controller is released
3. When chair is turned Off

In addition the power chair is fitted with attendant brakes for use when in free wheel (drive clutch disengaged).

## Anti-Tip Wheels

When anti-tip wheels are requested they are easily fitted to the rear motor mounting tubes by way of inserting into tube and locating button lock to fit into pre-drilled hole in motor mounting tube.



**Interference with kerbs may occur when anti-tip wheels are fitted.**



**Identifying Parts on your Wheelchair (Fig. 1)**

- |  |  |
|--|--|
| <ol style="list-style-type: none"> <li>1. Standard Non - Adjustable Height Armrests</li> <li>2. Battery Pack (with built in lifting strap)</li> <li>3. Drive Clutch</li> <li>4. Attendant Brakes</li> <li>5. Pneumatic Front Castor Wheels<br/>200mm x 50mm (8" x 1 1/4")</li> <li>6. Pneumatic Rear Wheels<br/>203mm x 62mm (12 1/2" x 2 1/4")</li> </ol> | <ol style="list-style-type: none"> <li>7. Swing Away Footrests</li> <li>8. Dynamic Shark Controller</li> <li>9. High Torque Motors</li> <li>10. Folding Frame</li> <li>11. Sail Cloth Upholstery</li> <li>12. Velcro Calf Strap</li> </ol> |
|--|--|

**Maximum Safe Slope** = 12 Degrees moving  
**Maximum Obstacle Climbing** = 48mm forward  
 36mm backwards with anti-tip wheels fitted

# The Battery

Keeping the Power Chair working to its maximum potential, it is recommended the batteries be charged every night. This will ensure a longer life for the batteries and the chair will be ready to go when you are.

Your Power Chair battery charger is special to your chair and may not be suitable for other power chairs.

# Charging Your Power Chair

1. Ensure charger is switched off
2. Ensure wheelchair is switched off
3. Connect charger to wheelchair via the charging socket located on the front of the joystick module.
  - ORANGE “Battery Connected” light will come on
  - Connect 3 Pin plug to mains supply and turn on.
  - Switch charger on. RED “Power On” light will come on.
  - When battery is fully charged GREEN (charge complete) float light will come on.

**NOTE:** Chargers may vary slightly so please familiarise yourself with the manufacturers instructions.

# Charging Times

Charging times may vary depending on usage, battery condition, internal resistance and age of battery. In most cases overnight charging (8 – 10 hours) is sufficient.

No harm will be done to batteries by leaving them on charge for a few days. However, prolonged charging is not advisable e.g. 3 days or more.

# Charger Specifications

Input – 240V/AC 150V/AC 50Hz

Output – 24V/DC @5A

# Batteries

Do not store near a heat source or in direct sunlight. Keep the terminals dry, clean and coat lightly with petroleum jelly to prevent corrosion. If batteries are leaking or faulty never dispose of into general waste. Take care when handling damaged batteries and avoid contact of acid with bare skin.

If acids make contact with skin or clothing, wash immediately with soap and water. All batteries are deemed to be hazardous waste when they are no longer useful and you should contact your local authority for recycling. It is advisable to have a Glide Rehabilitation Products representative replace your batteries.

## Battery Specification

### **(Sonnenschein A212/24G5 Sealed Lead Acid)**

Volts 12V/DC

Ah 24

C20

Max Current for 5 Sec 800A

(See Section 15 for connection details)

Output – 24V/DC @5A

## SECTION 8 | ROUTINE MAINTENANCE

# Routine & Scheduled Maintenance

### Weekly

1. Check tyre pressures  
Front = 206KPA (30PSI)  
Rear = 241KPA (35PSI)
2. Clean frame and vinyl parts with mild soapy solution.
3. Wipe upholstery with a clean damp cloth
4. Check function of electric brakes
5. Check all cables and connectors are secured; i.e. battery, motors and controller.

### Monthly

1. Give the chair a general inspection for loose nuts and bolts.
2. Inspect and clean corrosion from battery terminals and cable connectors.  
Coat with petroleum jelly

### Annually

It is advisable to have an annual inspection of the Power Chair performed by an authorised Glide Rehabilitation Products Agent. Their knowledge and experience enables them to identify and correct problems that might otherwise go undetected. For any questions concerning procedures or service, contact your nearest Glide Rehabilitation Products Agent or Glide Rehabilitation Products direct.

**NOTE:** As stated in our warranty, we recommend that your wheelchair be returned to an authorized Glide Rehabilitation Products agent for its free 3 month service check. This is a one off free service calculated from date of purchase.



## SECTION 9 | TROUBLE SHOOTING

# Loss of Power

If your Power Chair will not go, follow this checklist:

1. Check that the lights on control box are illuminated.
2. Of there are no lights on controller, check that all leads/plugs, which connect to controller, are pushed in properly.
3. Check that the motor cables are properly connected.
4. Check all battery wiring is connected.
5. Check that battery box connector is plugged in.
6. Check circuit breaker located on the battery box lid. The circuit breaker will trip when the wheelchair is stalled for a prolonged period or if a major fault has occurred. If circuit breaker continually trips for no apparent reason, cease use and contact nearest Glide Rehabilitation Products service agent.  
**Important:** Allow 60 seconds before resetting circuit breaker.
7. If you still have problems after reviewing the above checklist, please contact your nearest Glide Rehabilitation Products Agent or Glide Rehabilitation Products direct.

## SECTION 10 | DYNAMIC SHARK CONTROLLER

# SHARK Controller Controls

**On/Off Touch Pad** – This is a GREY pad located at rear left hand side of the controller – behind the joystick.

**Turning the Shark ON** – Press the power button. All indicators will light briefly and will either show battery charge or Lock Mode.

**Turning the Shark OFF** – Press the power button. All LED's will turn off.

**Sleep Mode** – Shark controllers may be supplied with the SLEEP feature that automatically turns off the Shark if no joystick movement is detected within a certain period (programmable).

When Wake Style has been set to “Joystick and Buttons”, pressing any button or displacing the joystick will bring the system out of Sleep mode.

When the Wake Up style has been set to Buttons only, pressing the On/Off button ONLY will bring the system out of Sleep mode.

**Driving SHARK** – Moving the joystick will cause the powerchair to move in that direction. The amount of joystick movement will determine the speed that the powerchair will move in that direction.

A user may adjust the top speed of their powerchair to suit their individual needs or environment by turning the speed control dial.

Simply turn the speed control dial fully clockwise to travel at top speed when the joystick is pushed fully forward.

The top speed is progressively reduced as the speed control dial is turned counter clockwise.

All driving parameters (speed, acceleration, etc) can be further programmed to suit individual needs and preferences of each user.

**Using the Horn** – Press the Horn Button located at the front of the Shark controller in front of the joystick – Grey button. The Horn will sound for as long as the button is pressed.

**Locking the Shark** – Some Sharks may be supplied factory programmed with a Lock feature to prevent unauthorized people from turning the Shark on.

**To Lock Shark** – While the power is On, press and hold the power button for 2 seconds. The display will turn off immediately. After 2 seconds all LED's will flash briefly and the horn will sound a short beep. The powerchair will then turn off.

**To Unlock Shark** – While Shark is Locked, press the On/Off button to turn Shark On. All LED's will flash briefly. The LED's will then perform a slow right to left countdown. Press the Horn button twice before the countdown has completed (approximately 10 seconds). The current state-of-charge will then be displayed and Shark may be operated normally.

**Charging Shark** – Plug the battery charger into the charging socket located at the front of the Shark unit. The Shark information gauge will indicate the system is being charged by cycling between a left to right 'chase' and displaying the current battery state of charge. Driving is prevented (inhibited) while the system is being charged. Once the battery charger has displayed a 'full' battery charge, the battery charger may be removed.

**NOTE:** If Shark is turned off, or goes into Sleep mode while charging, charging will continue. Although the Shark information gauge will display an approximate battery level while charging, the battery charger should be used as the sole judge of charge completion.

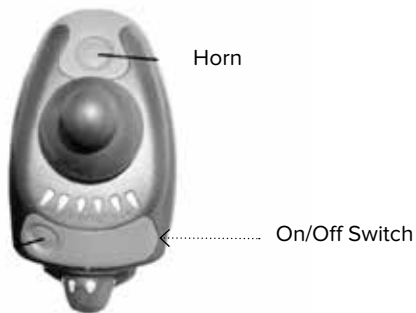
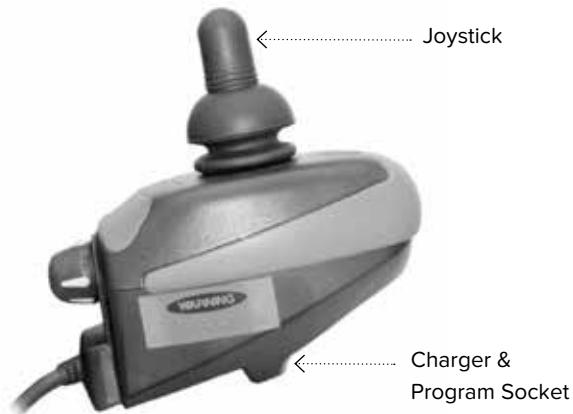

## SECTION 11 | PRECAUTIONS FOR CONTROLLER USE

# SHARK Controller Controls

The Dynamic controller has been designed with the user safety as the prime consideration. They incorporate many, sophisticated self-test features which search for potential problems. If the controller detects a problem either in its own circuits or in the wheelchairs electrical system, it may decide to halt the wheelchair depending on the severity of the fault. The controllers are designed to maximise the user safety under all normal conditions.



**Unauthorised programming of the chair may cause the chair to drive in an erratic and dangerous manner.**

The controller would have been programmed to suit your individual needs. If changes are required to this original setting it is recommended that you contact an authorised Glide Rehabilitation Products agent.

In spite of their sophistication, the controllers cannot take into account circumstances which put the wheelchair or controller outside their specified operating conditions, and so it is important that the user follows the following precautions:

1. Do not drive the wheelchair:
  - Beyond restrictions indicated in the User Manual.
  - In places or on surfaces where a loss of wheel grip could be hazardous, for example on wet grassy surfaces.
  - If the controller or other crucial components are known to require repair.

In the event of the wheelchair moving in an unexpected manner release the joystick. This action will stop the wheelchair under all circumstances.

2. Although the controllers are designed and manufactured to be extremely reliable and each unit rigorously tested, possibility of a system malfunction always exists (however small the probability). Under some conditions of detected system malfunction, the controller must (for safety reasons) stop the chair instantaneously. If the physical impairments of the user are such that a sudden braking action could result in a fall from the chair, it is advised that a restraining device be fitted.
3. It is recommended that a restraining device be used when operating the Power Chair.



**Dynamic Controls and Glide Rehabilitation Products accept no liability for losses of any kind arising from unexpected stopping of the wheelchair or improper programming of the controller or improper use of the wheelchair or controller.**

## Transferring In and Out

The Glide Rehabilitation Products Power Chair is designed in such a way that transferring in and out can be done with a minimum of fuss.

1. Armrests can either be removable or flipped back (depending on type specified when ordering) allowing easy lateral movement from either side of chair or for the fitting of a patient hoist sling.
2. If occupant is ambulant or able to do standing transfers, removing swing away footplates will allow better placement of feet when standing or conversely, closer access to seat when transferring into chair.
3. Where possible have someone assist you during the transfer.
4. You will need to learn safe transfer techniques from your health professional.
5. Always have chair as close as possible to chair that you are transferring to.
6. Ensure that the front castors are facing forward when transferring.
7. Ensure that your wheelchair brakes are applied

# User Safety

The Glide Rehabilitation Products Power Chair has been designed and tested with user safety as it's prime consideration and complies with AS 3695 Standards. Even though the Series 4 has been designed with user safety as it's prime consideration, this does not negate the effect or take into account circumstances which put the wheelchair outside the specified operating conditions for which it was designed and tested.

It is important that the user takes due care and understands the limitations within the environment that the chair will be operated.

As a guide only, the following is a brief list of scenarios that could affect the stability of the chair and need to be considered when driving chair:

- Traction could be lost on inclined, wet, grassy surfaces.
- Traversing railway lines should be done with someone in attendance with occupant.
- If your environment has many steep obstacles, it is advised that an anti-tip wheel be fitted to your chair.
- If there is a concern for occupant sliding forward out of chair, it is advised that a suitable restraining device may need to be fitted. Consult your health professional for advice on restraining device. If there is a need for a lap type posture restraining belt to be fitted to the Series 4 Power Chair we recommend that you contact your nearest agent or Glide Rehabilitation Products direct for correct fitting procedures.
- Take care when accessing door thresholds. Changes in floor height can stop castors and cause chair to tip.



**The Series 4 Power Chair is capable of climbing slopes greater than the maximum safe slope stated. Glide Rehabilitation Products recommends that care should be taken when slopes in excess of the maximum safe slope are being accessed as the centre of balance of your wheelchair changes when on a slope. Never use your chair on a slope unless you are sure it is safe.**

For more advice contact your nearest Glide Rehabilitation Products agent.

## SECTION 14 | RADIO FREQUENCY INTERFERENCE

# RFI

Most electronic equipment is influenced by Radio Frequency Interference (RFI). Caution should be exercised with the regard to the use of portable communications equipment in the area around such equipment. While the manufacturer has made every effort to ensure that RFI does not cause problems, very strong signals could still cause a problem. If RFI causes erratic behaviour, shut the wheelchair off immediately. Leave Off while transmission is in progress.

In the event of a fault indicator flashing while driving (battery gauge and/or Status LED), the user must ensure that the system is behaving normally. If not, the system must be turned Off and a service agent contacted.

The Glide Rehabilitation Products Series 4 Power Wheelchair has been tested to and passes EMC requirements stated in EN 12184.

In addition to this it has passed ENV50204:1995 for Radiated Electromagnetic Field from Digital Radio Telephones Immunity Tests.

Even though the chair has passed these tests there is always the chance, no matter how unlikely this may be, that the chair's performance could be influenced by electromagnetic fields.

It is recommended that the wheelchair power source be turned Off when using equipment that emits electromagnetic fields i.e. portable telephones and other emitting devices.

It is also important to note that the electromagnetic field emitted by the Series 4 Power Chair may cause interference to other electromagnetic fields in its vicinity i.e. alarm systems etc.

SECTION 15 | BATTERY WIRING DIAGRAM

# How to Wire the Battery

**Recommended Batteries**

2 x 12V 24 Amp HR

Maintenance Free Rechargeable Sealed Batteries

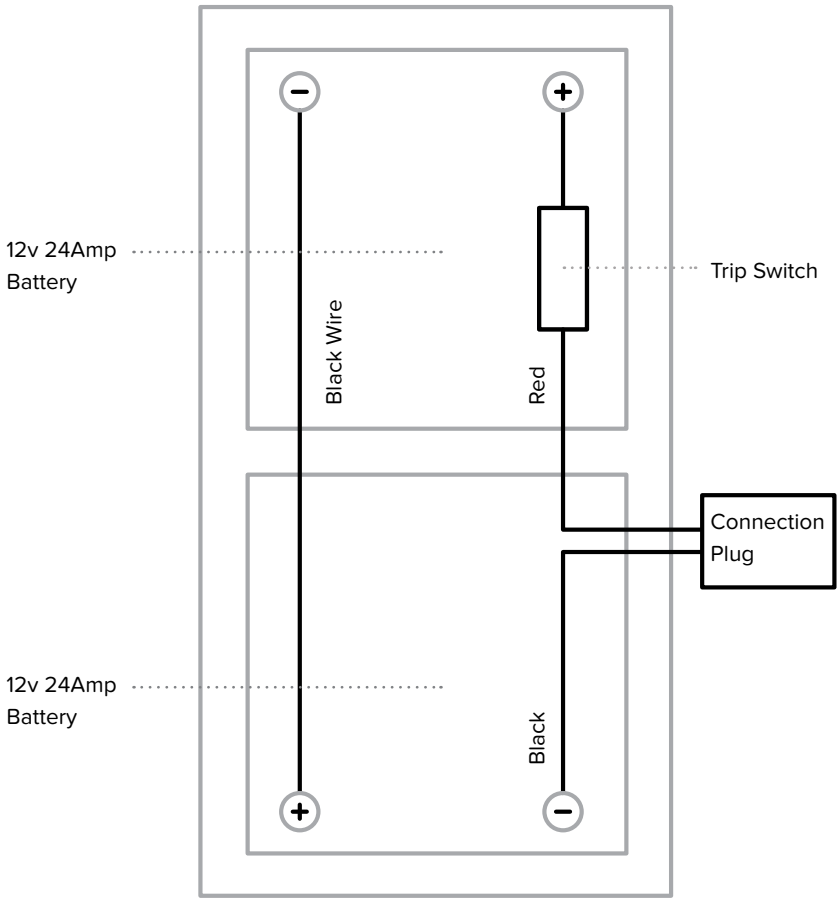



## SECTION 16 | SPARE PARTS

# Parts Library

### Tyres

200mm (8") Pneumatic Front	– P/N 202602
250mm (10") Pneumatic Front	– P/N 202670
203 x 62 (12 ½ x 2 ¼) Rear	– P/N 202615
4.10/3.50 – 6 Rear	– P/N 202663

### Tubes

200mm (8") Front	– P/N 202492
4.10/3.50 – 6	– P/N 202567
250mm (10") Front	– P/N 202566
203 – 62 (12 ½ x 2 ¼)	
Rear Thorn Proof.	– P/N 202501

### Castor Pintle Axle Assembly

Dust Cap	– P/N 77081
Circlip	– P/N 7803
Top Nylon Bush	– P/N 60390
Pintle Axle	– P/N 600145 or 600146
Bottom Bearing Housing	–P/N 60061
Bearing	– P/N 20017
Top & Bottom	
Castor Fork Retaining Nuts	– P/N 62000
Castor Fork	– P/N 200722
Castor Wheel	– P/N 20125
Bearing Spacer	–P/N 60627
Castor Wheel Bearings	– P/N 20024
Spacer Washers	– P/N 7827
Axle Bolt	– P/N 78732
Nyloc Axle Retaining Nut	– P/N 783841

# Caster Assembly Diagram

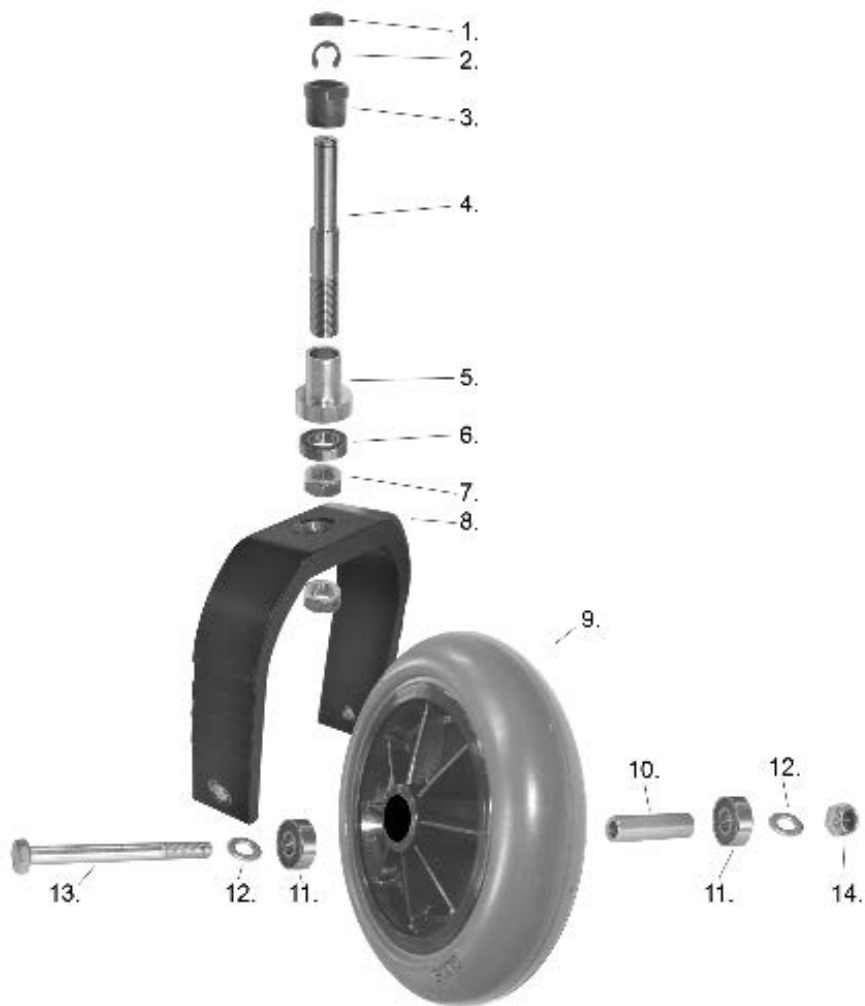

## SECTION 17 | WARRANTY

# Lendal Pty Ltd Warranty

Lendal Pty Ltd (trading as Glide Rehabilitation Products) warrants the following as listed:

**Controllers** - 12-months warranty

Controllers and associated hardware will be repaired where possible. Replacement will only occur if repair is not practical or not possible.

**Motors/Gearbox** - 12-months

Automatic replacement within six months of invoice. There afterwards, unit must be returned for evaluation and possible repair before replacement.

**Actuators** - 12 months warranty.

Automatic replacement within six months of invoice. There afterwards, unit must be returned for evaluation and possible repair before replacement.

**Frame** - 3-year warranty

S4 Frame sub-assembly or part of will be replaced.

**Upholstery** - 6 month warranty

This will cover against defects in materials or workmanship. Warranty does not cover against normal wear or damage.

**Tyres and Tubes** - No Warranty

**Spare Parts**

All spare parts sold will have a 6 months warranty period from date of purchase. This warranty does not extend to parts or electrical components damaged by misuse, neglect, accident or improper installation, nor those tampered with, altered or serviced by an agency not authorised by Lendal Pty Ltd.

The foregoing in lieu of all other warranties expressed, implied or statutory, Lendal Pty Ltd's sole liability shall be to repair or replace parts of components as specified above.

## **IMPORTANT**

1. Lendal Pty Ltd does not warrant either expressly or impliedly the suitability of the Glide Series 4 electric wheelchair for the purchaser or any intended user. Purchasers and intended users are advised that advice from an appropriate registered medical practitioner should be obtained prior to using an electric wheelchair.
2. Except insofar as is prohibited by statute, Lendal shall not be responsible for damage, injury or loss of any kind to any property or person howsoever caused arising from or in connection with the Glide Series 4. All conditions and warranties that (but for this provision) would be implied in favour of, and all rights and remedies that (but for this provision) would be conferred upon the purchaser or other persons against Lendal arising under or as a result of the Trade Practices Act 1974, any other legislation or the general law are excluded and limited to the maximum extent possible and in cases where Lendal's liability cannot be completely excluded but may be limited, the liability of Lendal is limited to one of the following (at the option of Lendal)
  - (a) The replacement of the Glide Series 4 or the supply of an equivalent wheelchair
  - (b) The repair of the Glide Series 4
  - (c) The payment of the cost of replacing the Glide Series 4 or of acquiring an equivalent wheelchair
  - (d) The payment of the cost of having the Glide Series 4 repaired



25 Ledger Rd Balcatta  
Western Australia 6021  
Phone: +61 8 9345 3400  
Web: [www.glide.com.au](http://www.glide.com.au)

Glide Products Pty Ltd

ABN: 28 645 050 255

ACN: 645 050 255

ISO 9001 ACCREDITED